



MADE IN BRITAIN

VERINE

FIRES TO INSPIRE



GAS FIRES
2018

BFM Europe Limited,
Trentham Lakes, Stoke-on-Trent, Staffordshire ST4 4TJ
Telephone: 01782 339000
email: info@bfm-europe.com



www.verinegasfires.co.uk

Go direct to the Verine website on your smart phone or tablet device, just scan in this QR code.



Issue 19a

MADE IN BRITAIN



Welcome to Verine

At Verine we know how important it is to create a stylish and relaxing living environment. That's why we've developed this collection of premium gas fires to complement all tastes and lifestyles.

"I believe our success stems from a combination of innovative design, investment in technology and the highest quality manufacturing standards.

As a result all Verine fires carry a 15 year guarantee to reflect my belief in their quality and durability, and our experienced Verine retailers are hand-picked to give you the very best advice and service.

This brochure has been designed to make the purchase of your new Verine fire as simple as possible. I hope you will find it both informative and inspiring."



Michael Dwyer

Find your perfect fire

Verine 15 year guarantee	3
Fires to inspire	4
Before you begin	5
Fire accessories – fascias, frets & trims	54-55
Power flue fires – installation possibilities.....	56-57



Our 15 year guarantee†

From design stage to manufacture every effort is taken to produce an appliance that will provide exceptional and continued standards of safety and performance. Every fire is assessed and approved by leading independent organisations and rigorously checked by our Quality Control department before leaving our state-of-the-art facility.

Therefore, we are confident you'll be enjoying the warmth of a Verine fire for many years to come. That's why we are able to provide a remarkable 15 year Guarantee† with every gas fire, giving you reassurance and peace of mind. We will guarantee your fire for 15 years* against manufacturing and material defects, including parts and labour, subject to proof of annual service and replacement of the oxy-pilot assembly.

*Terms and conditions apply.



This logo signifies that the product is fully compliant with the Eco design directive Commission Regulation (EU) 2015/1188.



Verine is crafted by BFM Europe, the fastest growing domestic fire producer in the country with an unequalled reputation for quality and service. Every Verine branded gas fire is developed and manufactured in Britain at our purpose built, state-of-the-art facility in Stoke-on-Trent.

high efficiency



Conventional flue	6
Wall Inset – Glass Fronted	
Celena	8-9
Atina HE	10-11
Eden HE	12-13
Eden Elite	14-15
Hearth Inset – Glass Fronted	
Passion HE	16-17
Midas HE	18-19
Quasar HE	20-21
Frontier HE†	22-23
Orbis HE	24-25
Meridien HE†	26-27
Fireplace Suites – Glass Fronted	
Avignon Celena Suite	28-29
Lille Celena Suite	30-31
Rennes Celena Suite	32-33
Avignon Eden Elite Suite	34-35



Hearth Inset – Open Fronted	
Midas Plus	36-37
Quasar Plus	38-39
Orbis Plus	40-41
Orbis	42-43
Balanced flue	7
Wall Inset – Glass Fronted	
Celena BF	8-9
Atina BF	10-11
Eden Elite BF	14-15
Hearth Inset – Glass Fronted	
Meridien BF†	26-27
Elyse BF	44-45
Alpena BF	46-47
Fireplace Suites – Glass Fronted	
Avignon Celena BF Suite	28-29
Avignon Eden Elite BF Suite	34-35

†Wall inset option available.



standard fires

Conventional & Powerflue	7
Hearth Inset – Open Fronted	
Quasar & Quasar Powerflue	48-49
Frontier & Frontier Powerflue	50-51
Acclaim	52-53



VERINE

FIRES TO INSPIRE

Beautiful fires, designed to allure

Choose a Verine fire and all your expectations will be fulfilled. Elegant, sophisticated and designed to perfection.

Verine fires are all this and more. Crafted to not only captivate and beguile, they are built to the highest standards, are energy efficient and perform brilliantly.

Expect optimum quality & performance from your fire

Verine fires are built to last in our state-of-the-art UK manufacturing facility where our quality standards meet the stringent demands of ISO 9001/2000. That's why we are able to offer an impressive 15 year Guarantee on all gas fires.

Every fire in the range features a Flame Supervision Device (FSD) which detects the presence of a flame, and in the absence of that flame, prevents uncontrolled release of gas to the burner. For maximum safety each conventional flue model also includes an Oxygen Depletion Sensor (ODS) which shuts off the gas supply to the main burner in the unlikely event of a fault.

We recommend that all gas appliances be serviced by a Gas Safe Register engineer to ensure continued safe operation and optimum performance throughout the lifetime of the product. In order to encourage and promote this good practice, an annual service, including replacement of the oxy-pilot, is a condition of our 15 year Guarantee.

Expect the highest level of after sales service & expert advice

For over 45 years Verine have sold quality products and given quality service, elegance and innovation to the fireplace industry. Specially appointed retailers have been established nationally to display our products, install them and give expert advice to help you choose the correct appliance to suit your needs.

We want you to get the maximum benefit from this expertise and therefore recommend you avoid purchasing any Verine product over the internet, especially from companies not located in your area who are unable to offer the highest levels of aftersales service.

bsi. Product Testing & Certification

All our gas fires are independently tested, approved and verified by the British Standards Institution (BSI).

The BSI is an independent organisation. They are not owned by the government, industry or shareholders, which means that they can be totally objective with regards testing and certification. This gives their assessments more authority than those of an organization that has a vested interest in promoting its members.

They have some of the most experienced and knowledgeable staff in the world and are recognised internationally for their technical expertise, quality services and in-depth knowledge of gas and electrical product testing and certification.

The wide-ranging capability of their testing facilities and the broad expertise and knowledge of their testing and certification staff ensures our products are rigorously tested with the utmost integrity.

Before you begin

There is a Verine fire for all tastes, from traditional to contemporary chic. However, before you make your final selection, please take time to consider the following.

RADIANT OR CONVECTOR?

A radiant fire emanates heat from the combustion chamber only, which is why Verine radiant fires incorporate a glowing back panel to maximise heat output. A convector fire has the added benefit of a heat exchanger attached to the back of the fire. This draws cold air in and sends it back out into the room as hot air, maximising heat output whilst keeping your fuel bills down.

CHIMNEY OR FLUE?

Your choice of fire will be dictated by the type of chimney or flue you have. If you're not sure, then take a look at your roof and cross-reference it with the simple guide below. It is also worth noting that a slimline fire will fit virtually any chimney or flue, whereas a full-depth often requires a traditional chimney or rebate on the fire surround.



Brick Chimney
A conventional brick chimney is easily recognisable by a chimney stack with accompanying terracotta pot or gas terminal.



Pre-Fabricated Flue
This is an interlocking metal flue tube system easily identifiable by a metal flue and terminal on the roof and a metal flue box behind the fire.



Pre-Cast Flue
Built from concrete or clay blocks, pre-cast flues provide a rectangular section flue. They can be identified by a ridge vent or metal flue tube and terminal on the roof. All fires featuring this icon are suitable for pre-cast flues conforming to BS EN 1858.

NO CHIMNEY OR FLUE?

Some properties have no chimney or flue, in which case a balanced flue or powerflue is required.



Powerflue fires expel the flue gases directly outside the building through the use of an electronically driven fan unit inset on the external wall. A sophisticated microprocessor monitors performance and automatically shuts off the fire in the unlikely event of operation failure.

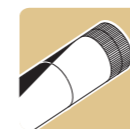

Balanced Flue fires vent directly outside through a co-axial pipe (one pipe within a larger pipe). The outer pipe draws air in from the outside and the inner pipe expels combustion gases. An electricity supply is not required for these products. Please see installation manuals for further details about installation possibilities.

GAS SUPPLY

Your gas supply will either be Natural Gas or LPG, depending on the area in which you live.



Natural Gas
The most common gas supply



LPG
Alternative for houses with no Natural Gas supply

CONTROLS

Gas is wonderfully controllable, but which type of control suits you best? The discretion of manual ignition, concealed behind the removable ash pan... the convenience of slide control... or the luxury and style of remote control?



Manual Control
Simple and discreet. The control system is located behind the fire's fret or trim. Once the fire is lit rotate the control knob to adjust the flame height and heat output.



Slide Control
A convenient control system which is located on the top right-hand side of the fire. Push and hold the lever down to ignite and move it up and down to adjust the flame height and heat output.



Easy Flame Control (EFC) - Discreet, easy access buttons are used to ignite the fire and adjust heat and flame height.



Remote Control
The remote control handset is used to light the fire as well as to adjust the flame height and heat output.



Remote Control with Thermostat
The remote control handset can be used to light the fire as well as to adjust the flame height and heat output. In addition, the handset contains the extra benefit of a thermostatic control to regulate room temperature and a programmable timer that can be pre-programmed to ensure your room will be warm whenever you wish.

FIRE BACK PANELS

Some Verine fires offer you a choice of fire back panels – simply choose the one that suits your room from the options available.



Plain Black



Brick Effect



Ribbed Black



Ribbed Cream



Cream Vermiculite



Glossy Black Enamel



Matt Black Enamel

high efficiency Get up to 93.5% energy efficiency

from a Verine high efficiency gas fire

Verine has always had a reputation as a manufacturer of some of the most efficient fires on the market. Now we are setting new industry standards with the Verine high efficiency range: exceptional heat output combined with lower running costs compared to standard gas fires.

Verine's R&D team has invested in developing the technology to meet the key objective of producing gas fires that save energy and as a result, help to keep costs down.

Inspired design. Advanced technology

Our glass fronted high efficiency Conventional and Balanced Flue fires are available in a range of Wall Inset and Hearth Inset models as well as Fireplace Suites. In addition, we have a range of open fronted high efficiency Conventional Flue Hearth Inset fires offering more options and choices.



Lille Celena Fireplace Suite..... Pages 30-31

standard fires

Conventional and Powerflue Fires

Hearth Inset – Open Fronted Fires

Standard fires can achieve a direct heat output of up to 3.1kW. It is recommended that these products are not suitable for use as a primary heat source but they are ideal if you are looking for a great fireplace feature for occasional use.



Acclaim Hearth Inset..... Pages 52-53



79.6%
energy efficiency

Celena Wall Inset..... Pages 8-9



84.3%
energy efficiency

Frontier HE Hearth Inset..... Pages 22-23

Conventional Flue fires

Glass Fronted Fires

Our range of high efficiency conventional flue glass fronted fires have an energy efficiency of up to 86%. They have a glass panel across the front of the fire which radiates the heat generated from the fuel bed directly into the room. The glass panel concentrates the radiant heat so that more heat is forced into the room and less is lost through the chimney. Combined with convected heat which is produced by cool air drawn into the base of the fire through the heat exchanger and then emitted as warm air through the gap above the canopy, making these the most efficient conventional flue fires available.

Open Fronted Fires

Our high efficiency conventional flue open fronted fires can reach an energy efficiency of up to 68.3%. These fires provide the look and feel of a real open fire providing both radiant and convected heat. Radiant heat is emitted from the coal effect fuel bed and the convected heat is generated by cool air drawn into the base of the fire which passes through a heat exchanger and is then emitted as warm air through the gap above the canopy.

Balanced Flue fires

Glass Fronted Fires

Our range of high efficiency balanced flue fires have an energy efficiency of up to 93.5%. Designed for those who want all the benefits of a gas fire but don't have a built in chimney or flue in their home, a balanced flue fire comes with its own flue terminal which is vented directly through an outside wall. They are glass fronted, completely room sealed appliances and work by drawing and venting external air via a pair of co-axial tubes into the fire for combustion purposes.



66.7%
energy efficiency

Orbis Plus Hearth Inset..... Pages 40-41



93.5%
energy efficiency

Alpena BF Hearth Inset..... Pages 46-47

high efficiency Conventional & Balanced Flue

Wall Inset – Glass Fronted



Celena

The Celena gas fire has been designed to be suitable for homes with or without a brick chimney or pre-fabricated flue. Featuring non reflective glass that presents a crystal clear perfectly proportioned large viewing area, displaying tall and lively attractive flames.

The slimline balanced flue option has an impressive energy efficiency of 90.5% and comes with an attractive lower fuel bed log arrangement.

The conventional flue option offers a raised log fuel bed and has an energy efficiency of 79.6%. The Celena comes complete with a thermostatic remote control to ensure your room is always at a comfortable temperature.

A polished silver, brass, or black trim is available to purchase as an optional extra.

SPECIFICATIONS

Description: Full depth inset gas fire Type of Heat: Radiant & Convected

	Conventional Flue	Balanced Flue
Useful energy efficiency	79.6%	90.5%
Energy efficiency class	D	B
Fuel type	Natural gas	Natural gas
Direct heat output	3.9kW	3.9kW

Fuel Effect	Back Panel	Model Number	
Log	Matt Black	NPRLPBRN	NCBLPBRN
	Cream Vermiculite	NPRLTVRN	NCBLTVRN

Safety: Flame Supervision Device & Oxygen Depletion Sensor Air vent required: Not normally

DIMENSIONS – CONVENTIONAL FLUE

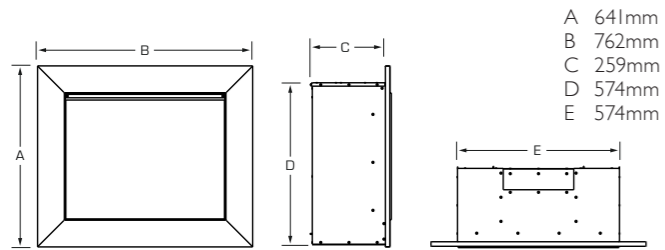

- A 641mm
- B 762mm
- C 259mm
- D 574mm
- E 574mm

Slimline Balanced Flue dimensions on page 58.

OPTIONS

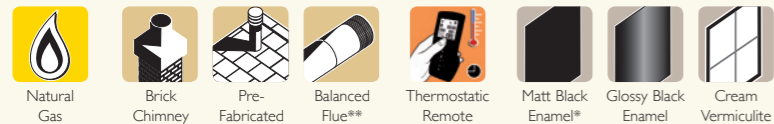

*Matt enamel only available on balanced flue model **Balanced flue fire requires an 80mm spacer when installing into a standard cavity wall. Model no. I184-1001079A

ALTERNATIVES



Celena conventional flue with cream vermiculite fire back and brass effect trim



Celena conventional flue with glossy black enamel fire back and black painted trim



Shown: Celena Slimline BF with matt black enamel fire back and polished silver trim

Celena conventional flue



Watch the video



Watch the video

high efficiency Conventional & Balanced Flue

Wall Inset – Glass Fronted



Atina HE

Atina HE's perfect petite proportions and fabulous black reflective interior combined with a spellbinding flame makes this little hole-in-the-wall gas fire a magnificent centre-piece for smaller modern living areas.

The Atina HE features a heat output of 3.3kW and is controlled by a fully sequential remote control system* with thermostatic operation so you can always maintain a comfortable room temperature that suits you.

*A 240V 3amp mains electricity supply is required. Please refer to installation manual.

SPECIFICATIONS

Description: Full depth inset gas fire Type of Heat: Radiant & Convected

	Conventional Flue	Balanced Flue
Useful energy efficiency	70.8%	72.8%
Energy efficiency class	F	F
Fuel type	Natural gas	Natural gas
Direct heat output	3.3kW	3.3kW

Fuel effect	Control type	Model Number	
Log/White Stones	Remote	NHAL00RN	NHBL00RN2

Safety: Conventional Flue – Flame Supervision Device & Oxygen Depletion Sensor
Balanced Flue – Flame Supervision Device
Air vent required: Not normally

DIMENSIONS

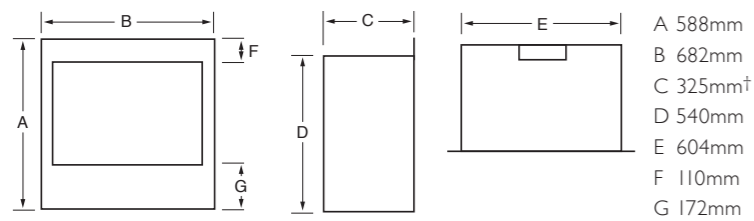

Wide fascia

- A 485mm
- B 800mm
- C 15mm

†This dimension is related to Atina HE CF only and is 370mm on Atina HE BF

OPTIONS

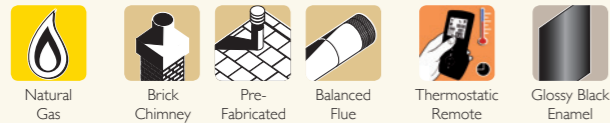

ALTERNATIVES



Trimless with white stones



Wide antique brass fascia and logs



Shown: Atina HE with a polished silver fascia and white stones

high efficiency Conventional

Wall Inset – Glass Fronted



Eden HE

This glass fronted landscape hole-in-the-wall fire has an incredible 84.3% energy efficiency and up to 4.8kW heat output. It features an enchanting flame picture and comes with a choice of log or white stone fuel bed. The Eden HE has been designed as a trimless* fire for a very minimalist appearance, or team with an optional designer trim for a more prominent centrepiece.

*A 240V 3amp mains electricity supply is required to power the remote control system. Please refer to installation manual.

SPECIFICATIONS

Description: Full depth inset gas fire Type of Heat: Radiant & Convected

Useful energy efficiency	83%	
Energy efficiency class	D	
Fuel type	Natural gas	
Direct heat output	5.2kW	
Fuel effect	Control type	Model Number
Log/White Stones	Remote	NHVG00RN

Safety: Flame Supervision Device & Oxygen Depletion Sensor
Air vent required: Not normally

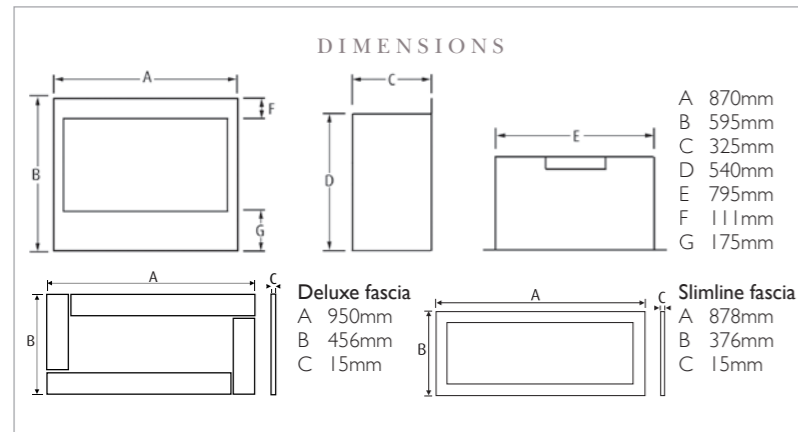

OPTIONS

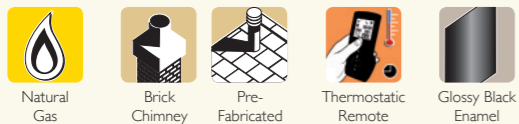

ALTERNATIVES



Eden HE with Polished Steel Slimline fascia and white stones. Also available in Antique Brass



Eden HE Deluxe Antique Brass fascia with logs



Shown: Eden HE trimless with logs



Watch the video

high efficiency Conventional & Balanced Flue

Wall Inset – Glass Fronted



Eden Elite

The Eden Elite is our slimmest hole-in-the-wall gas fire with up to 85.6% energy efficiency and an impressive 4.9kW heat output. It is operated by a thermostatic remote control system to perfectly control your comfort.

The conventional flue model is designed to be easily installed into almost any chimney without compromising on the stunning log fuel bed and flame aesthetics. It comes in a choice of cream vermiculite or glossy black enamel back panel.

There is also a slimline balanced flue model for homes without a chimney or flue which is only available with a glossy black enamel back panel.

The Eden Elite is a non reflective glass fronted fire that can be fitted with or without a trim. Trim options are available in brushed steel, or black powder coated finish.

SPECIFICATIONS

Description: Slimline inset gas fire Type of Heat: Radiant & Convected

	Conventional Flue	Balanced Flue
Useful energy efficiency	78.6%	69%
Energy efficiency class	D	E
Fuel type	Natural gas	LPG
Direct heat output	4.9kW	4.3kW

Fuel Effect	Back Panel	Model Number		
Log	Glossy Black	NEEELLRN	NEEELLRP	NEELOORN
	Cream Vermiculite	NEELVLRN	NEELVLRP	n/a

Safety: Conventional Flue – Flame Supervision Device & Oxygen Depletion Sensor
Air vent required: Not normally

DIMENSIONS – CONVENTIONAL FLUE

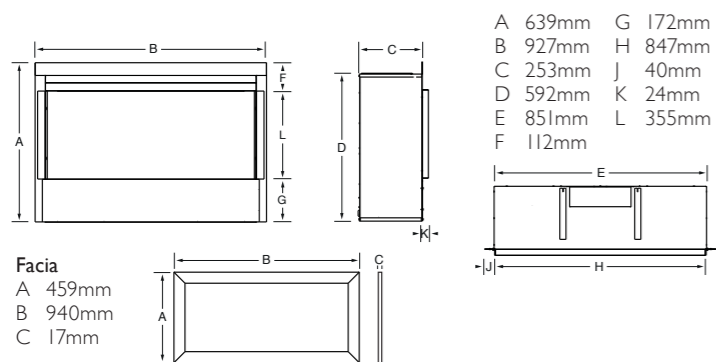

Slimline Balanced Flue dimensions on page 58.

OPTIONS

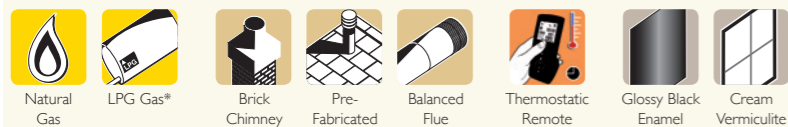

ALTERNATIVES



Eden Elite with brushed steel trim and glossy black enamel panels



Eden Elite with cream vermiculite tiled effect back panel and black powder coat trim



Eden Elite Slimline conventional flue



Watch the video

Shown: Eden Elite Slimline BF with glossy black enamel back panel and black powder coat trim



Watch the video

high efficiency Conventional Flue

Hearth Inset – Glass Fronted



Passion HE

Passion HE is a beautiful gas fire with a truly authentic looking log effect fuel bed. With its large viewing window it features stunning flame motion that captivates as it dances and reflects in the glossy black enamel interior.

For optimum aesthetics this fire can be supplied with non reflective glass that provides an astonishingly crystal clear view of the fuel bed. For comfort and performance choose our fully automatic and thermostatic remote control option. A manual control version is also available.

The Passion HE is available with a choice of specifically designed contemporary one-piece fascia options, the Ultimo 007 in three colour finishes, gold, black nickel and silver, and the Provence cast iron fascia in black.

For a more traditional two-piece arrangement we have introduced a uniquely designed Bauhaus 151 fret. Combine this with the tasteful Ultimo trim to further complement the wide viewing angles of this fire. Alternatively you can combine this fret with other Verine trim options – see page 55.

SPECIFICATIONS

Description: Full depth inset gas fire Type of Heat: Radiant & Convected

	Manual	Remote	
Useful energy efficiency	82.3%	82.6%	79.7%
Energy efficiency class	D	C	D
Fuel type	Natural gas	Natural gas	LPG
Direct heat output	4.0kW	4.0kW	3.6kW
Fuel effect	Model Number		
Log	NLBL00MN	NLBL00RN	NLBL00RP

Safety: Conventional Flue – Flame Supervision Device & Oxygen Depletion Sensor
Air vent required: Not normally

OPTIONS

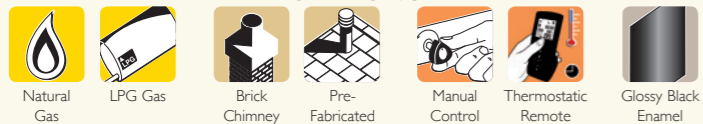

DIMENSIONS

Passion Fascias

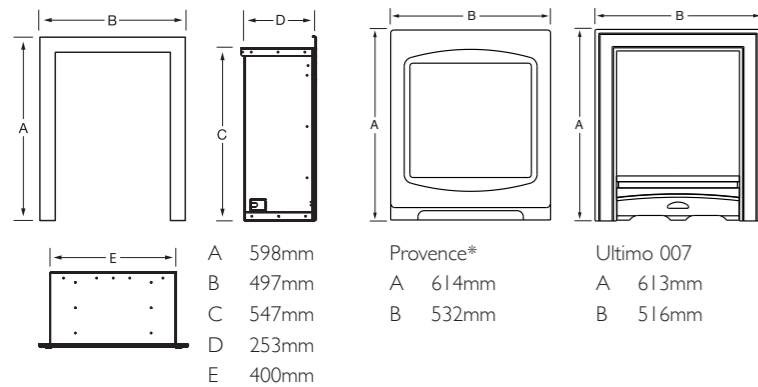

Dimensions A & B refer to Standard trim only *Remote control option only

ALTERNATIVES



Passion HE with Ultimo 007 fascia in Gold. Also available in Black Nickel and Silver

Passion HE Ultimo trim and Bauhaus 151, shown in Black Nickel and Silver. Also available in Gold finish.



Shown: Passion HE with Provence black cast iron fascia (available with remote control only)



Watch the video

high efficiency Conventional Flue

Hearth Inset – Glass Fronted



Midas HE

This slimline high efficiency fire boasts an energy efficiency of up to 81.3% and will fit almost any chimney or flue including pre-cast (BS EN 1858).

It also features a large viewing window and offers an incredible 2.9kW heat output. A pebble effect fuel bed is available as an optional extra.

SPECIFICATIONS

Description: Slimline inset gas fire Type of Heat: Radiant & Convected

	Manual	Slide
Useful energy efficiency	81.3%	
Energy efficiency class	D	
Fuel type	Natural gas	
Direct heat output	2.9kW	
Fuel effect	Model Number	
Coal	NSHC00MN	NSHC00SN2

Safety: Flame Supervision Device & Oxygen Depletion Sensor
Air vent required: Not normally

OPTIONS



Natural Gas



Brick Chimney



Pre-Fabricated



Pre-Cast



Manual Control



Slide Control



Plain Black

DIMENSIONS

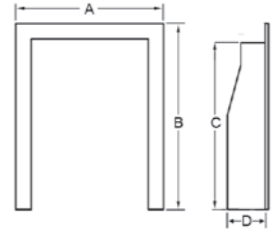

A	497mm
B	598mm
C	550mm
D	125mm
E	327mm

Dimensions A & B refer to Standard trim only

ALTERNATIVES



Midas HE with pebble fuel bed



Shown: Midas HE with Designer silver and black trim and Elegance polished fret

high efficiency Conventional Flue

Hearth Inset – Glass Fronted



Quasar HE

The Quasar HE offers an impressive energy efficiency of up to 84.3% and features one of the most realistic coal fuel beds on the market.

This glass fronted product has been designed to fit in to most chimney and flue types, including pre-cast flue when installed with a 3" rebated fire surround. Manual, slide and remote control options are available to choose from and a pebble fuel effect is available as an optional extra.

SPECIFICATIONS

Description: Full depth inset gas fire **Type of Heat:** Radiant & Convected

	Manual	Slide	Remote
Useful energy efficiency	84.3%		84.3%
Energy efficiency class	D		C
Fuel type	Natural gas		Natural gas
Direct heat output	3.4kW		3.4kW

Fuel effect	Model Number		
Coal	NHKC00MN	NHKC005N	NHKC00RN2

Safety: Flame Supervision Device. **Air vent required:** Not normally

OPTIONS



Natural Gas



Brick Chimney



Pre-Fabricated



Pre-Cast



Manual Control



Slide Control



Thermostatic Remote



Plain Black

DIMENSIONS

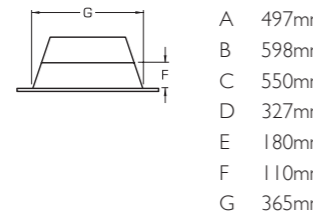
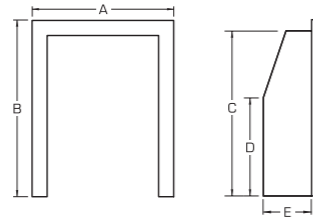

- A 497mm
- B 598mm
- C 550mm
- D 327mm
- E 180mm
- F 110mm
- G 365mm

Dimensions A & B refer to Standard trim only

ALTERNATIVES



Quasar HE with pebble fuel effect and Arcadia fascia in chrome



Shown: Quasar HE with coal fuel effect and Arcadia fascia in brass

high efficiency Conventional Flue

Wall & Hearth Inset – Glass Fronted



Frontier HE

The Frontier HE is the epitome of modern day living combining the benefits of a highly efficient gas fire with sleek contemporary styling. Frontier HE is available as a hearth inset or hole-in-the-wall fire with a choice of three fascia colours; black and polished silver, champagne or bronze and champagne. A pebble effect fuel bed is available as an optional extra.

SPECIFICATIONS

Description: Full depth inset gas fire Type of Heat: Radiant & Convected

	Manual	Remote
Useful energy efficiency	84.3%	84.3%
Energy efficiency class	D	C
Fuel type	Natural gas	Natural gas
Direct heat output	3.4kW	3.4kW

Fuel effect	Model Number	
Coal	NHKC00MN + Fascia	NHKCRBRN2 + Fascia

Safety: Flame Supervision Device. Air vent required: Not normally

Fascia	Colour	Part Number
Hearth	Black/silver	B-123540
	Bronze/champagne	B-135220
	Champagne	B-135230
Wall	Black/silver	B-123550
	Bronze/champagne	B-135240
	Champagne	B-135250

OPTIONS



Natural Gas



Brick Chimney



Pre-Fabricated



Pre-Cast



Manual Control*



Thermostatic Remote



Plain Black

*only available on hearth inset models

DIMENSIONS

Hearth Mounted

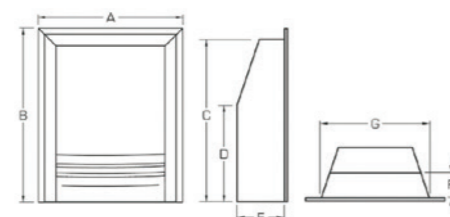

A 541mm	D 327mm	G 365mm
B 620mm	E 180mm	
C 550mm	F 110mm	

Wall Mounted

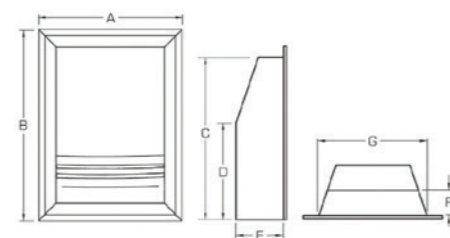

A 541mm	D 327mm	G 365mm
B 690mm	E 180mm	
C 550mm	F 110mm	

ALTERNATIVES



Frontier HE Hole-in-the-wall in champagne with pebbles



Frontier HE Hole-in-the-wall in bronze/champagne with coals



Shown: Frontier HE
Hearth Inset in black/
silver with coals

high efficiency Conventional Flue

Hearth Inset – Glass Fronted



Orbis HE

Orbis HE is a full depth high efficiency fire providing a heat output of up to 4.0kW and an incredible 86.3% energy efficiency. This glass fronted fire is available with a choice of manual, slide and remote control operation. Create your own look with our extensive range of trims and frets shown on pages 54-55.

SPECIFICATIONS

Description: Full depth inset gas fire Type of Heat: Radiant & Convected

	Natural gas	LPG
Useful energy efficiency	86%	86.3%
Energy efficiency class	C	C
Fuel type	Natural gas	LPG
Direct heat output	3.9kW	4.0kW

Fuel effect	Control type	Model Number	
Coal	Manual	NHEC00MN	n/a
	Slide	NHEC00SN	NHEC00SP
	Remote	NHEC00RN2	n/a

Safety: Flame Supervision Device & Oxygen Depletion Sensor
Air vent required: Not normally

OPTIONS



Natural Gas LPG Gas*



Brick Chimney Pre-Fabricated



Manual Control Slide Control Thermostatic Remote



Plain Black

*Slide Control only

DIMENSIONS

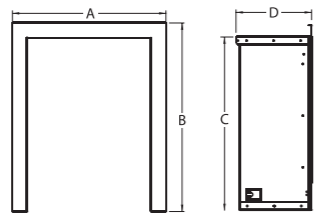

A 497mm
B 598mm
C 550mm
D 230mm
E 400mm

Dimensions A & B refer to Standard trim only



Shown: Orbis HE with Embrace Fascia in Gold

high efficiency Conventional & Balanced Flue

Wall & Hearth Inset – Glass Fronted



Meridian HE

A combination of contemporary fascia design and traditional log fuel bed is sure to make the Meridian an impressive feature in any home. This exceptionally versatile fire can be installed as a modern hole-in-the-wall fire or with a fire surround for a more traditional look. Choose between ribbed black, ribbed cream or brick effect fire back (flame picture will differ on balanced flue model).

SPECIFICATIONS

Description: Full depth inset gas fire Type of Heat: Radiant & Convected

	Conventional Flue	Balanced Flue
Useful energy efficiency	72.6%	83.9%
Energy efficiency class	E	C
Fuel type	Natural gas	Natural gas
Direct heat output	4.1kW	4.3kW

Fuel Effect	Back Panel	Model Number	
Log	Brick Effect	NHELBBRN2	NBFLBBRN2
	Ribbed Black	NHELBRN2	NHFLBRN2
	Ribbed Cream	NHELRCRN2	NBFLRCRN2

Safety: Conventional Flue – Flame Supervision Device & Oxygen Depletion Sensor
Balanced Flue – Flame Supervision Device
Air vent required: Not normally

DIMENSIONS

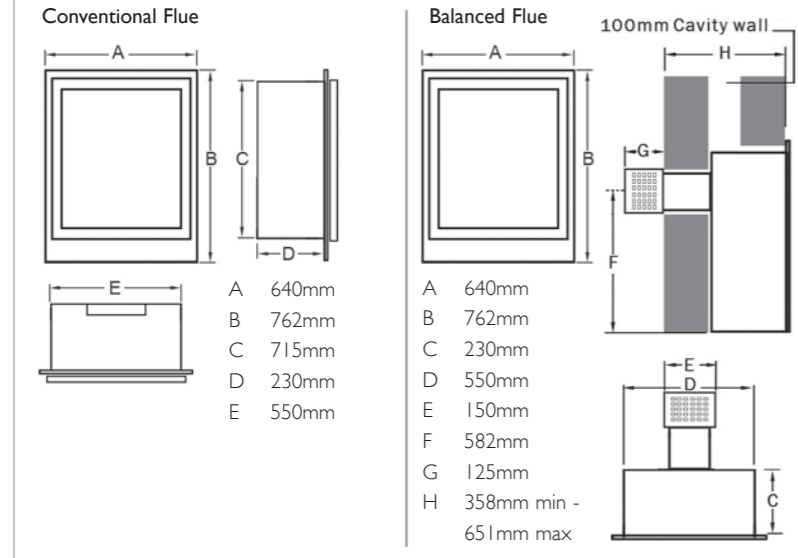

OPTIONS



TRIM ALTERNATIVES



Shown: Meridian as hearth inset installation with Cream ribbed back fibres and Champagne fascia



Watch the video

high efficiency Conventional & Balanced Flue

Fireplace Suite – Glass Fronted



Avignon Celena Suite

The Avignon Gas Fire Suite is beautifully crafted in natural Portuguese Limestone, combining traditional style and modern taste into one classically designed fireplace.

Featuring the beautiful conventional flue Celena gas fire which is a highly efficient glass fronted fire designed to be suitable for homes with a brick chimney or pre-fabricated flue.

The slimline balanced flue option boasts an impressive 90.5% energy efficiency rating with a direct heat output of 3.9kW. This model features an attractive lower level log fuel arrangement whilst the conventional flue option has a raised log fuel bed and has an energy efficiency of 79.6%.

A thermostatic remote control system allows you to pre-set your desired room temperature. Both flue versions come with non reflective glass and interior panels are available in a choice of matt and glossy black enamel, or cream vermiculite.

SPECIFICATIONS

Description: Full depth inset gas fire Type of Heat: Radiant & Convected

	Conventional Flue	Balanced Flue
Useful energy efficiency	79.6%	90.5%
Energy efficiency class	D	B
Fuel type	Natural gas	Natural gas
Direct heat output	3.9kW	3.9kW

Fuel Effect	Back Panel	Model Number	
Log	Matt Black	NPRLPBRN810	NCBLPBRN720
	Cream Vermiculite	NPRLTVRN810	NCBLTVRN720

Safety: Flame Supervision Device & Oxygen Depletion Sensor
Air vent required: Not normally

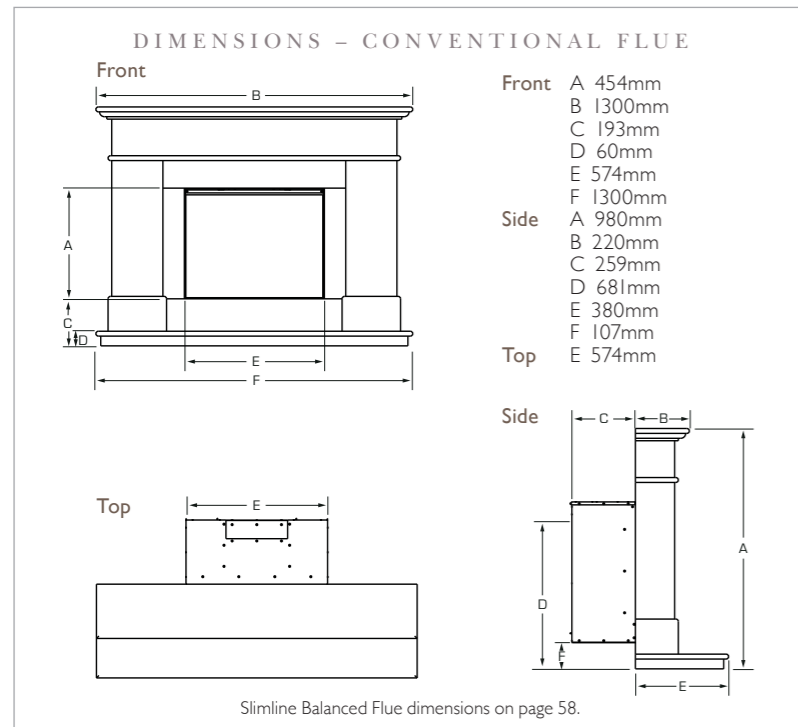

OPTIONS

- Natural Gas
- Brick Chimney
- Pre-Fabricated
- Balanced Flue
- Thermostatic Remote
- Matt Black Enamel*
- Glossy Black Enamel
- Cream Vermiculite

*Matt enamel only available on balanced flue model

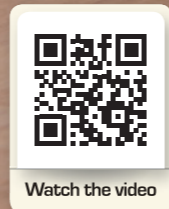

Avignon Suite & Celena gas fire with cream vermiculite fire back

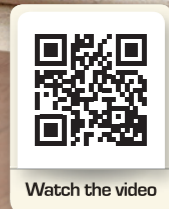

Avignon Suite & Celena Slimline BF gas fire with matt black enamel fire back panels

high efficiency Conventional Flue

Fireplace Suites – Glass Fronted



Lille Celena Suite

The Lille fire surround suite is made from the finest quality Portuguese limestone in a contemporary design that features a chamfered recess frame designed to draw the eye into a large viewing area with its attractive display of tall lively flames.

It comes with the stunning Celena gas fire. This non reflective glass fronted fire features a beautiful raised style log effect fuel bed and has an incredible 79.6% energy efficiency. It is operated by a fully automatic remote control system which allows you to select the times you want the fires to automatically turn on and turn off and includes a thermostatic setting to allow you to pre-set your desired room temperature.

It is suitable for installation into most standard chimneys and has a choice of glossy black enamel or cream vermiculite back panels.

SPECIFICATIONS

Description: Full depth inset gas fire Type of Heat: Radiant & Convected

Useful energy efficiency	79.6%
Energy efficiency class	D
Fuel type	Natural gas
Direct heat output	3.9kW

Fuel Effect	Back Panel	Model Number
Log	Matt Black	NPRLPBRN695
	Cream Vermiculite	NPRLTVRN695

Safety: Flame Supervision Device & Oxygen Depletion Sensor
Air vent required: Not normally

DIMENSIONS

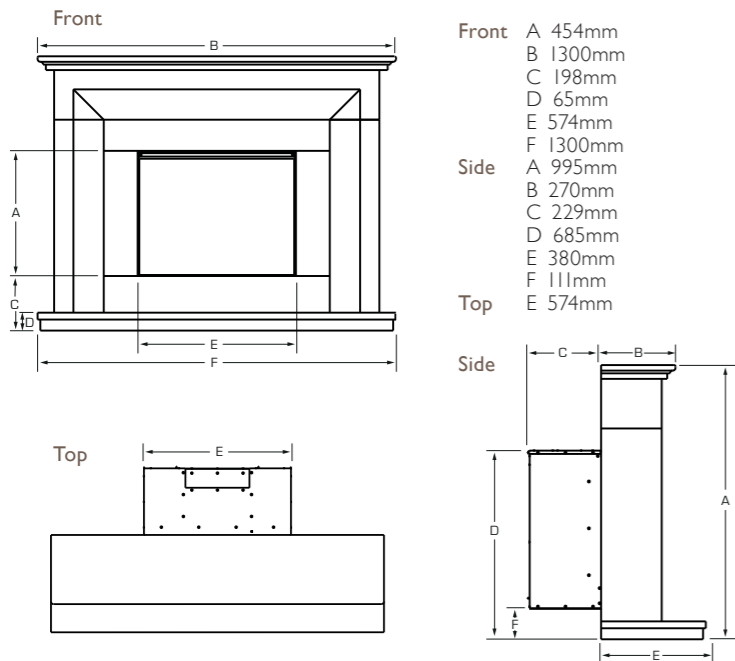

OPTIONS

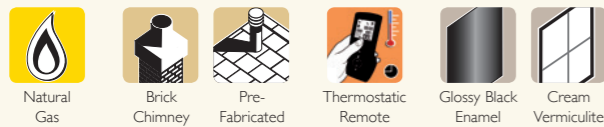

Shown: Lille Suite & Celena gas fire with matt black enamel back panels

Watch the video

high efficiency Conventional Flue

Fireplace Suites – Glass Fronted



Rennes Celena Suite

The Rennes Gas Fire Suite features a sleek, modern design which is perfect for a more minimalist appearance and is made from the finest quality Portuguese limestone.

It comes complete with the perfectly proportioned Celena gas fire which is a highly efficient, non reflective glass fronted fire featuring a stunning raised style log effect fuel bed, a direct heat output of 3.9kW and 79.6% energy efficiency. It is suitable for installation into most standard brick chimneys and pre-fabricated flues.

It is also operated by a fully automatic remote control system which allows you to select the times you want your fire to automatically turn on and turn off and includes a thermostatic setting to allow you to pre-set your desired room temperature.

SPECIFICATIONS

Description: Full depth inset gas fire Type of Heat: Radiant & Convected

Useful energy efficiency	79.6%
Energy efficiency class	D
Fuel type	Natural gas
Direct heat output	3.9kW

Fuel Effect	Back Panel	Model Number
Log	Matt Black	NPRLPBRN790
	Cream Vermiculite	NPRLTVRN790

Safety: Flame Supervision Device & Oxygen Depletion Sensor
Air vent required: Not normally

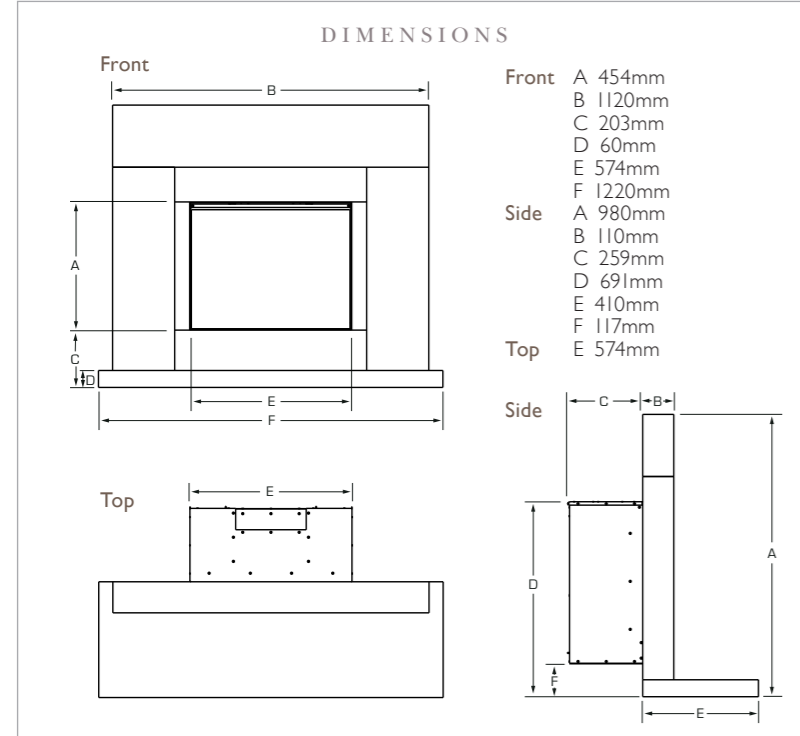

OPTIONS

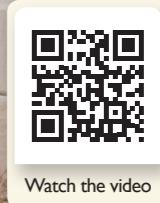
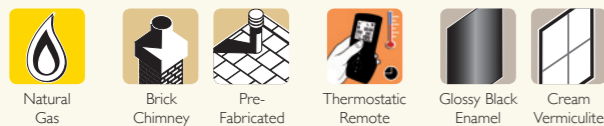

Shown: Rennes Suite & Celena gas fire with matt black enamel back panels

Watch the video

high efficiency Conventional & Balanced Flue

Fireplace Suites – Glass Fronted



Avignon Eden Elite Suite

This stunning fireplace suite comprises the classically styled Avignon surround in 54" or 58" wide versions, is made from high quality natural Portuguese limestone and includes the fabulous Eden Elite gas fire.

The slimline balanced flue option is suitable for installation into homes without a brick chimney or pre-fabricated flue and has an impressive energy efficiency of 85.6% and 3.7kW heat output. It features a glossy black enamel back panel.

The conventional flue option comes with a choice of glossy black enamel or cream vermiculite back panels and features a stunningly realistic raised log fuel bed. It has an energy efficiency of 78.6% and impressive heat output of 4.9kW.

Both models benefit from non reflective glass and are operated by a fully automatic and thermostatic remote control system so you can maintain a comfortable room temperature at the touch of a button.

SPECIFICATIONS

Description: Slimline inset gas fire Type of Heat: Radiant & Convected

	Conventional Flue	Balanced Flue
Useful energy efficiency	78.6%	85.6%
Energy efficiency class	D	C
Fuel type	Natural gas	LPG
Direct heat output	4.9kW	3.7kW

Fuel Effect	Back Panel	Model Number	
Log	Glossy Black 54"	NEEELRN890	NBELEBRN722
	Cream Vermiculite 54"	NEELVLRN890	n/a
	Glossy Black 58"	NEEELRN910	NBELEBRN779
	Cream Vermiculite 58"	NEELVLRN910	n/a

Safety: Flame Supervision Device & Oxygen Depletion Sensor
Air vent required: Not normally

DIMENSIONS – CONVENTIONAL FLUE

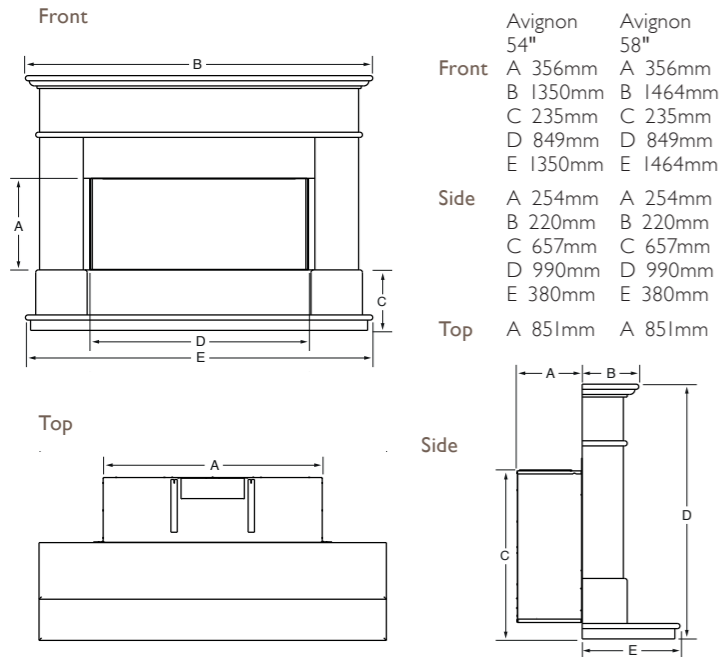

Slimline Balanced Flue dimensions on page 58.

OPTIONS

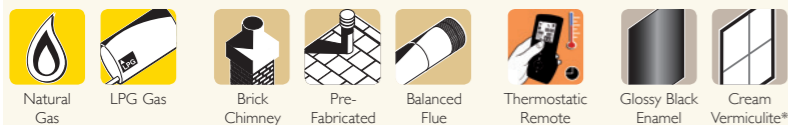

*Not available on Balanced Flue models

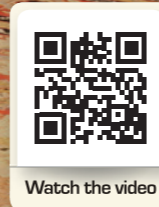

Shown: Avignon 58" Eden Elite conventional flue with cream vermiculite tiled effect back panels

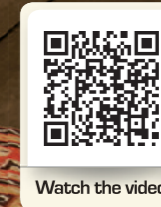

Shown: Avignon 54" Eden Elite Slimline balanced flue with glossy black enamel back panels

high efficiency Conventional Flue

Hearth Inset – Open Fronted



Midas Plus

The Midas Plus is one of the most efficient open-fronted slimline gas fires available today and with a heat output of up to 4.0kW it is also one of the warmest products suitable for a pre-cast flue.

The Midas Plus is available in a choice of manual or remote control systems. This extremely versatile fire can be styled with a wide range of Verine trims, frets or fascias and with an optional pebble fuel bed it is easy to create a look to suit your existing décor. See pages 54 to 55 for more information about Verine accessories.

SPECIFICATIONS

Description: Slimline inset gas fire Type of Heat: Radiant & Convected

	Manual	EFC	Remote
Useful energy efficiency	66.8%	66.8%	
Energy efficiency class	F		F
Fuel type	Natural gas		Natural gas
Direct heat output	4.0kW		3.8kW

Fuel effect	Model Number		
Coal/Pebbles	NSPC00MN	NSPC00TN2	NSPC00RN2

Safety: Flame Supervision Device & Oxygen Depletion Sensor
Air vent required: Not normally

OPTIONS



Natural Gas



Brick Chimney



Pre-Fabricated



Pre-Cast



Manual Control



Easy Flame Control



Remote Control



Plain Black

DIMENSIONS

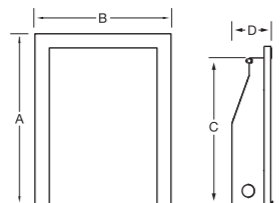

- A 600mm
- B 498mm
- C 548mm
- D 125mm
- E 324mm

Dimensions A & B refer to Standard trim only

ALTERNATIVES



Midas Plus with Profiled trim in silver, Bauhaus fret in polished silver and pebble fuel effect



Shown: Midas Plus with Profiled trim in brass, Bienenheim fret in brass and coal fuel effect



Watch the video

high efficiency Conventional Flue

Hearth Inset – Open Fronted



Quasar Plus

Quasar Plus high efficiency gas fire boasts an impressive 68.3% energy efficiency and can be installed in to almost any chimney or flue, including pre-cast when fitted with a 3" rebated fire surround.

This open-fronted gas fire features a highly realistic coal fuel effect and is available as a manual, slide or remote controlled fire. A pebble effect fuel bed can be purchased as an optional extra.

The Verine Quasar Plus can be styled with most trims, frets and fascias in our wide range of gas fire accessories on pages 54 to 55.

SPECIFICATIONS

Description: Full depth inset gas fire Type of Heat: Radiant & Convected

	Manual	Slide	Remote
Useful energy efficiency		68.3%	
Energy efficiency class	F		
Fuel type	Natural gas		
Direct heat output	4.2kW		
Fuel effect	Model Number		
Coal/Pebbles	NKPC00MN	NKPC00SN	NKPC00RN2

Safety: Flame Supervision Device & Oxygen Depletion Sensor
Air vent required: Not normally

OPTIONS



Natural Gas



Brick Chimney



Pre-Fabricated



Pre-Cast



Manual Control



Slide Control



Remote Control



Plain Black

DIMENSIONS

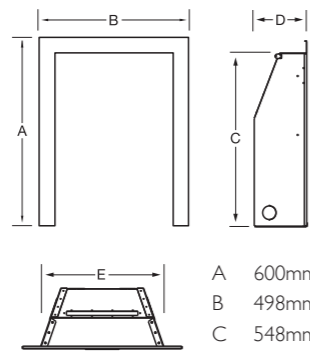

A 600mm
B 498mm
C 548mm
D 170mm
E 365mm

Dimensions A & B refer to Standard trim only

ALTERNATIVES



Quasar Plus with pebble fuel bed



Shown: Quasar Plus with Curved silver trim and Elegance silver fret

high efficiency Conventional Flue

Hearth Inset – Open Fronted



Orbis Plus

Orbis Plus is the first full depth open-fronted high efficiency gas fire from Verine. You can now achieve the look of a real open coal fire, combined with the convenience of gas fuel, at up to an incredible 66.7% energy efficiency.

This stunning fire features an extra wide coal fuel effect bed, a beautiful flame picture and offers up to an incredible 4.2kW heat output.

Suitable for installation into standard brick chimneys and pre-fabricated flues, the Orbis Plus comes in a choice of manual, slide or remote control and can be styled to suit your home with our wide range of trims and frets (see pages 54-55 for further details).

SPECIFICATIONS

Description: Full depth inset gas fire Type of Heat: Radiant & Convected

	Natural gas	LPG
Useful energy efficiency	66.7%	66.2%
Energy efficiency class	F	F
Direct heat output	4.1kW	4.2kW

Fuel effect	Control type	Model Number	
Coal	Manual	NOPC00MN	n/a
	Slide	NOPC00SN	NOPC00SP
	Remote	NOPC00RN2	n/a

Safety: Flame Supervision Device & Oxygen Depletion Sensor
Air vent required: Not normally

OPTIONS

- Natural Gas
- LPG Gas*
- Brick Chimney
- Pre-Fabricated
- Manual Control
- Slide Control
- Remote Control
- Plain Black

*Slide Control only

DIMENSIONS

- A 600mm
- B 498mm
- C 548mm
- D 223mm
- E 400mm

Dimensions A & B refer to Standard trim only



Shown: Orbis Plus with Gold Ultimo Trim and Bauhaus Fret

high efficiency Conventional Flue

Hearth Inset – Open Fronted



Orbis

With a maximum heat output of 3.7kW The Orbis is one of the warmest open-fronted convector fires in the Verine range. It features a mesmerising and highly realistic coal fuel bed making this product one of the closest things you can get to a real coal fire.

This model is available with a choice of manual, slide or remote control operation and a wide range of trims and frets (see pages 54-55) ensuring you'll get the product that is just right for you.

SPECIFICATIONS

Description: Full depth inset gas fire Type of Heat: Radiant & Convected

Useful energy efficiency	60%
Energy efficiency class	F
Fuel type	Natural gas
Direct heat output	3.7kW

Fuel effect	Control type	Model Number
Coal	Manual	NVICC00MN
	Slide	NVICC00SN

Safety: Flame Supervision Device & Oxygen Depletion Sensor
Air vent required: Not normally

OPTIONS



Natural Gas



Brick Chimney



Pre-Fabricated



Manual Control



Slide Control



Plain Black

DIMENSIONS

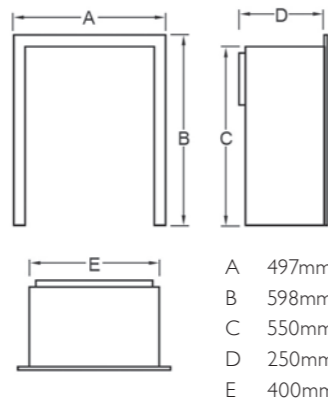

Dimensions A & B refer to Standard trim only

VERINE
15
YEAR GUARANTEE



Shown: Orbis with
Profiled Polished
Silver trim and
Polished Silver fret

high efficiency **Balanced Flue**

Hearth Inset – Glass Fronted



Elypse BF

The super slim Elypse Balanced Flue has been specifically designed for homes without a chimney and its slim depth allows it to be easily installed into a standard cavity wall. This glass fronted product has an incredible 80% energy efficiency and comes with a choice of brass, black or polished silver trim which can be complemented with your choice of any Verine fret (see pages 54-55).

SPECIFICATIONS

Description: Full depth inset gas fire Type of Heat: Radiant & Convected

Useful energy efficiency	80%	
Energy efficiency class	E	
Fuel type	Natural gas	
Direct heat output	2.7kW	
Fuel effect	Control type	Model Number
Coal	Manual	NBFC00MN

Safety: Flame Supervision Device
Air vent required: Not normally

OPTIONS



Natural Gas



Balanced Flue



Manual Control



Brick Effect

DIMENSIONS

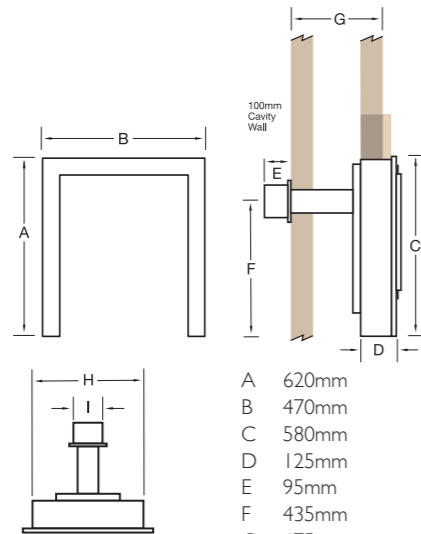

- A 620mm
- B 470mm
- C 580mm
- D 125mm
- E 95mm
- F 435mm
- G 675mm max
-130mm min
- H 400mm
- I 145mm

ALTERNATIVES



Elypse in brass with Elegance fret in brass



Elypse in silver with Media fret in polished silver



Shown: Elypse in black with Elegance black fret

high efficiency **Balanced Flue**

Hearth Inset – Glass Fronted



Alpena BF

Alpena Balanced Flue boasts up to 93.5% energy efficiency, it is a glass fronted fire featuring plain black panels and a deep coal fuel bed. The product can be styled with a variety of trims and frets available in the Verine range (see pages 54-55).

SPECIFICATIONS

Description: Full depth inset gas fire Type of Heat: Radiant & Convected

	Natural gas	LPG
Useful energy efficiency	93.5%	93.5%
Energy efficiency class	B	B
Direct heat output	3.9kW	4.0kW

Fuel effect	Control type	Model Number	
Coal	Manual	NBFC00MN2	NBFC00MP2
	EFC	NBFC00EN3	n/a
	Remote	NBFC00RN3	n/a

Safety: Flame Supervision Device Air vent required: Not normally

OPTIONS

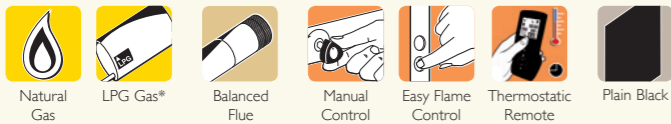

*Manual Control only

DIMENSIONS

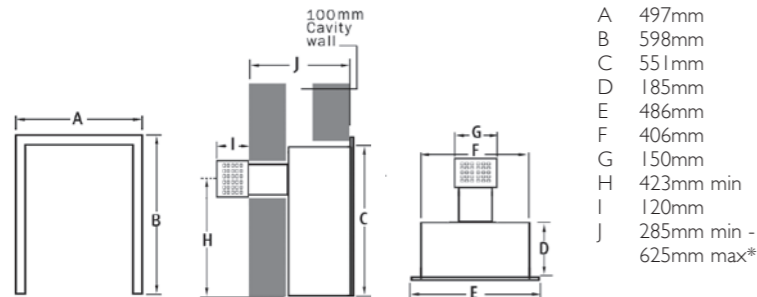

*Dimensions differ on EFC models. An optional flue duct extension is available to increase maximum length to 1015mm on manual models and 973mm on EFC models.



ALTERNATIVES



Alpena shown as hole-in-the-wall installation with Frontier fascia



Alpena with Frontier fascia in Silver/Black

Shown: Alpena with Brass trim and Bauhaus Brass fret



Quasar

Quasar has been specifically designed as a multi-installation fire and will fit most flue types including pre-cast when fitted with a 3" rebated surround. It is also suitable for installation into a standard chimney without the need to remove the chairbrick. A pebble fuel effect can be purchased as an optional extra and a power flue version is available for homes with no chimney or flue.

SPECIFICATIONS

Description: Full depth inset gas fire Type of Heat: Radiant

Conventional

Direct Heat Output	2.7kW
Fuel type	Natural gas

Fuel effect	Control type	Model Number
Coal	Manual	NRDCPBMN2
	Slide	NRDCPBSN2
	Remote	NRDCPBRN3

This product is not suitable for primary heating purposes

Powerflue

Useful energy efficiency	57.2%
Energy efficiency class	F
Fuel type	Natural gas
Direct heat output	3.6kW

Fuel effect	Control type	Model Number
Coal Powerflue	Manual	NVPCBMN2

Safety: Flame Supervision Device & Oxygen Depletion Sensor Air vent required: Not normally

OPTIONS



Natural Gas

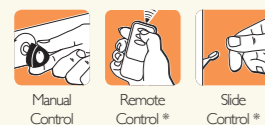
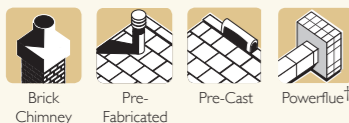

Plain Black

*Not available on Powerflue models
†Eco Design compliant Powerflue model only

DIMENSIONS

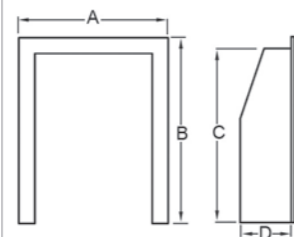

E	A 497mm
	B 598mm
	C 550mm
	D 170mm
	E 365mm

Dimensions A & B refer to Standard trim only

For Powerflue dimensions see page 56

ALTERNATIVES



Quasar with Profiled Silver trim, Bauhaus Polished fret and pebble fuel bed



Shown: Quasar with Silver trim, Bauhaus Polished fret and coal fuel bed



Frontier

This open fronted radiant gas fire features a contemporary one-piece fascia in a choice of black and polished silver, champagne or bronze and champagne fascia.

The Frontier has the option of manual or remote control operation and will fit in to most chimney and fuel types including pre-cast when installed with a 3" rebated fire surround. A pebble fuel effect is available as an optional extra.

SPECIFICATIONS

Description: Full depth inset gas fire Type of Heat: Radiant

Conventional

Direct Heat Output	2.7kW	
Fuel type	Natural gas	
Fuel effect	Control type	Model Number
Coal	Manual	NRDCPBMN2 + Fascia
	Remote	NRDCPBRN3 + Fascia

This product is not suitable for primary heating purposes

Powerflue

Useful energy efficiency	57.2%	
Energy efficiency class	F	
Fuel type	Natural gas	
Direct heat output	3.6kW	
Fuel effect	Control type	Model Number
Coal Powerflue	Manual	NVPCPBMN2 + Fascia

Safety: Flame Supervision Device & Oxygen Depletion Sensor Air vent required: Not normally

Fascia	Colour	Part Number
Hearth	Black/silver	B-123540
	Bronze/champagne	B-135220
	Champagne	B-135230
Wall	Black/silver	B-123550
	Bronze/champagne	B-135240
	Champagne	B-135250

OPTIONS



Natural Gas



Brick Chimney



Pre-Fabricated



Pre-Cast



Powerflue†



Manual Control



Remote Control*



Plain Black

*Not available on Powerflue models
†Eco Design compliant Powerflue model only

DIMENSIONS

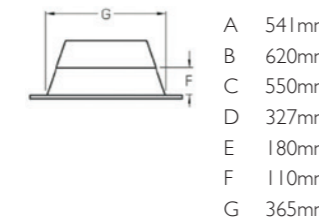
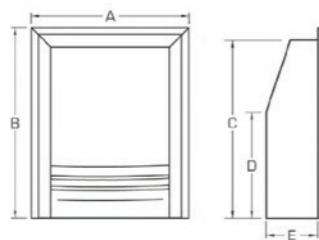

- A 541mm
- B 620mm
- C 550mm
- D 327mm
- E 180mm
- F 110mm
- G 365mm

For Powerflue dimensions see page 56



ALTERNATIVES



Frontier in Champagne



Frontier in Bronze/Champagne



Frontier in Polished Silver

Shown: Frontier with black and polished silver fascia

Acclaim

An ideal replacement for a real coal fire, the Acclaim is a tapered inset fire specifically designed to fit into existing firebacks. Flickering flames and a deep fuel bed glow create a highly realistic effect capturing the essence of a real open fire.

SPECIFICATIONS

Description: Full depth inset tray gas fire Type of Heat: Radiant

Fuel type	Fuel effect	Control type	Model Number
Natural gas	Decorative Flame Effect	Manual	NITC00MN3

Safety: Flame Supervision Device & Oxygen Depletion Sensor
 Air vent required: Not normally
 This product is not suitable for primary heating purposes

OPTIONS



Natural Gas



Brick Chimney



Pre-Fabricated



Manual Control

DIMENSIONS

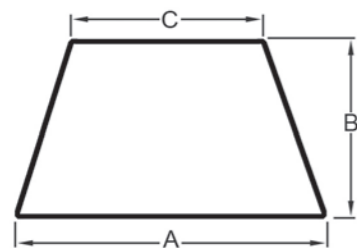

16"

- A 336mm
- B 200mm
- C 250mm



Shown: Acclaim with Bauhaus Black fret

Fire Accessories

Tailor your fire to match your living space

Make your Verine fire a unique fire. Choose your fascia, trim & fret and fuel bed from our divine selection to create a perfect match for your fire's setting.

Fascia options

Frontier Fascia

The Frontier is a one-piece contemporary fabricated steel fascia that is available in three stunning finishes.

The Frontier hearth inset fascia is suitable for all Verine hearth inset fires* excluding the Elypse.

The Frontier wall inset fascia is suitable for all Verine hearth inset fires excluding the Elypse.

HEARTH INSET



Black Painted/Silver Polished



Champagne



Bronze and Champagne Painted

WALL INSET



Black Painted/Silver Polished



Champagne



Bronze and Champagne Painted

Essence Fascia

The Essence is a one-piece contemporary fabricated steel fascia that is available in four finishes.

This fascia is suitable for the Midas, Midas Plus, Passion HE, Midas HE*, Orbis*, Orbis HE*, Quasar*, Quasar Plus*, and Quasar HE*



Antique Satin Brass



Antique Brass



Brushed Silver



Black Painted

Arcadia Fascia

The Arcadia is a one-piece cast iron fascia in a combination of black painted with optional colour plated finish. Suitable for Midas HE, Orbis HE, Passion HE, Quasar HE, Orbis Plus, Quasar Plus, Midas Plus, Orbis, Quasar and Alpena BF**



Gold Plated



Silver Plated

Embrace Fascia

The Embrace fascia is a one piece cast iron fascia in a combination of black painted and optional colour plated finish. Suitable for Orbis HE, Passion HE, Quasar HE, Midas HE, Orbis Plus, Quasar Plus, Midas Plus, Orbis, Quasar and Alpena BF**



Gold Plated



Silver Plated



Black Nickel Plated

Fret options

Each of these frets is suitable for every hearth inset gas fire in the Verine range. The black and polished silver frets are made from cast iron, and the brass and antique brass are made from solid brass.

Bauhaus 18"



Gold Plated



Silver Plated



Black Nickel Plated



Polished Silver



Black Painted

Bauhaus 151 18"



Gold Plated



Silver Plated



Black Nickel Plated

Blenheim 16"



Solid Antique Brass



Solid Brass



Polished Silver

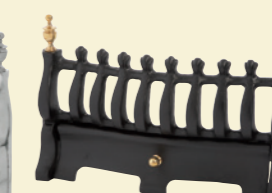

Black Painted

Elegance 16"



Solid Brass



Black Painted



Black & Chrome

Edwardian 16"

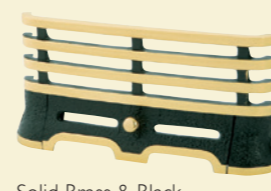

Solid Brass & Black

Media 16"



Solid Brass & Black



Polished Chrome & Black

Trim options

Standard trim



Brass Plated Black Painted Brushed Silver Plated Silver Plated

Quality steel trims in a choice of four colours. This trim is suitable for all Verine hearth inset fires, excluding the Elypse.

Profiled trim

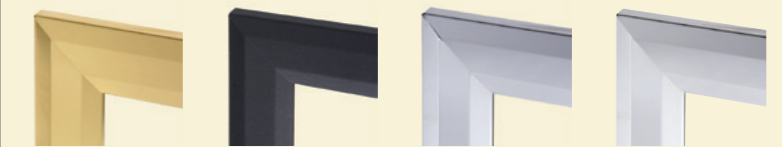

Brass Plated Black Painted Polished Silver Plated Brushed Silver Plated

The Profiled trim is made from steel and is available in brass, black and silver finishes. This trim is suitable for all Verine hearth inset fires, excluding the Elypse.

Ultimo trim



Gold Plated Silver Plated Black Nickel Plated

The Ultimo is a cast iron trim with a black painted and optional colour plated finish. Suitable for Orbis HE, Quasar HE, Midas HE, Orbis Plus, Quasar Plus, Midas Plus, Orbis, Quasar, Alpena BF** and Passion HE.

Curved trim



Brass Black Silver

The Curved trim is made from a high quality extruded aluminium and is available in anodised brass, anodised silver and black painted finishes. The Curved trim is suitable for all Verine hearth inset fires * excluding the Elypse.

Designer trim



Brass & Black Black & Brass Brass Silver Black & Silver Silver & Black

Made from extruded anodised aluminium, Designer trims create fabulous dual-coloured looks in a choice of six combinations. Suitable for all Verine hearth inset fires excluding the Elypse.

*Not available for slide control models **Not available with EFC models

The Verine Power Flue System

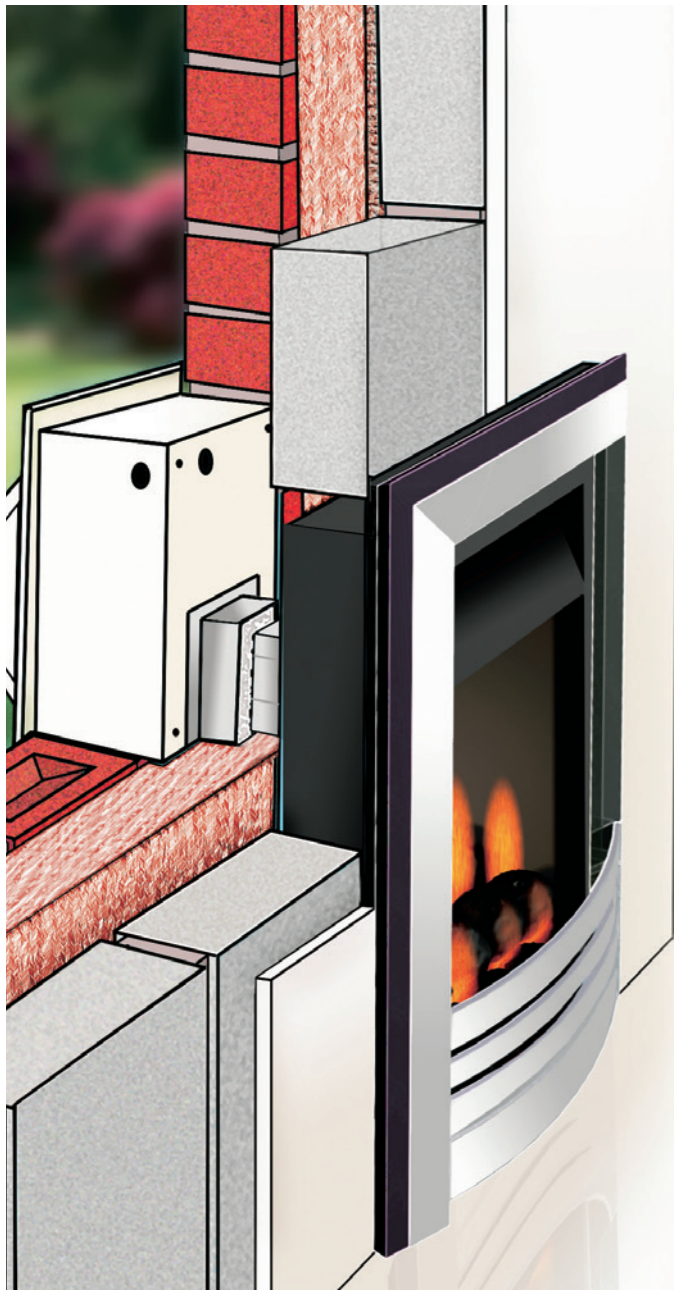

A gas fire creates a welcoming heart to any living room but many newer homes are being built without a chimney or flue so a conventional gas fire is not an option.

However, Power Flue gas fires have been specifically designed for homes without a conventional flue system providing a gas fuelled alternative heat source to an electric fire or radiator.



The Verine Slimline Fan System fully recessed into an outside wall leaving only a discreet 3" projection. 96mm and 183mm spacers are available if required.

BASIC POWER FLUE INSTALLATION EXAMPLE

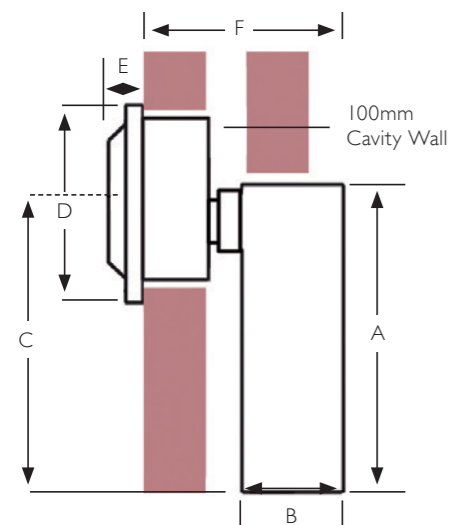
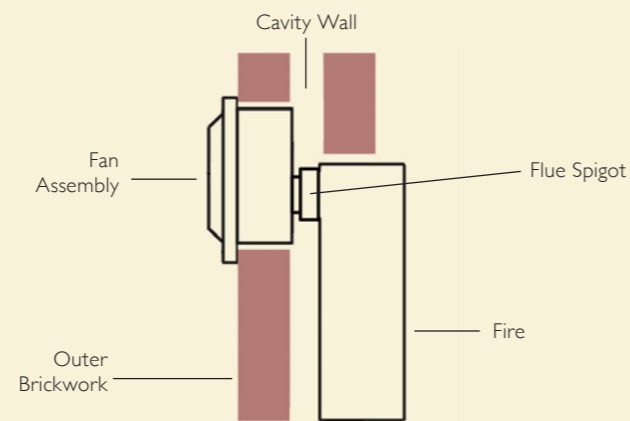

DIMENSIONS OF POWERFLUE FIRES

	Quasar/Frontier
A	547mm
B	179mm
C	482mm
D	360mm
E	78mm
F Min/Max	570-715mm

Installation Possibilities

The drawings below show a selection of the many possible installation situations.

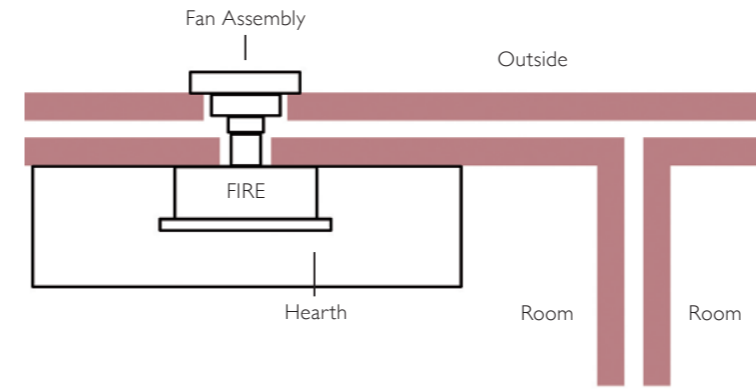

An example of a standard powerflue installation. The gas fire is flued directly through an outside wall via a straight, horizontal length of flue.

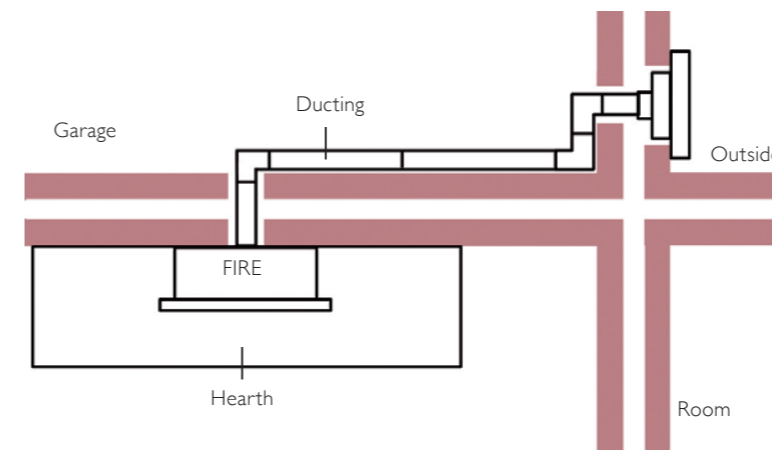

An example of a powerflue installation using three bends.

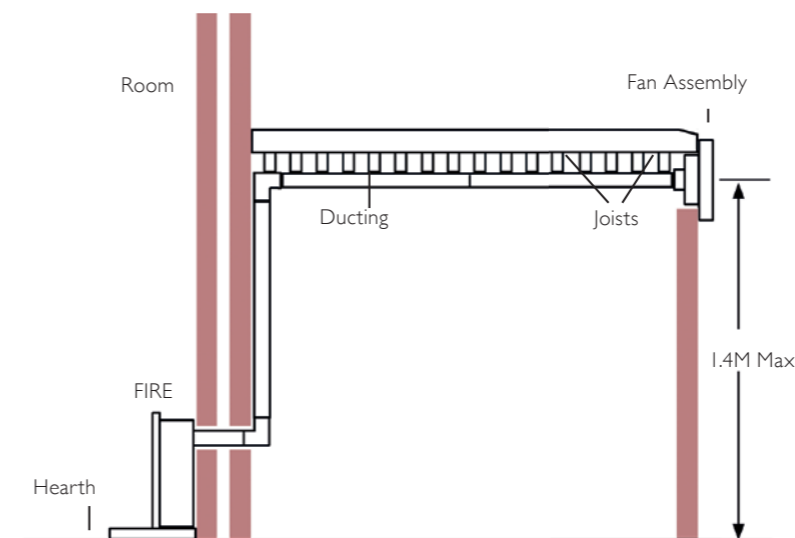

An example of a powerflue installation using a vertical section of flue pipe and two bends.

Balanced Flue Drawings & Dimensions

Celena Slimline Balanced Flue Wall Inset
– Page 8

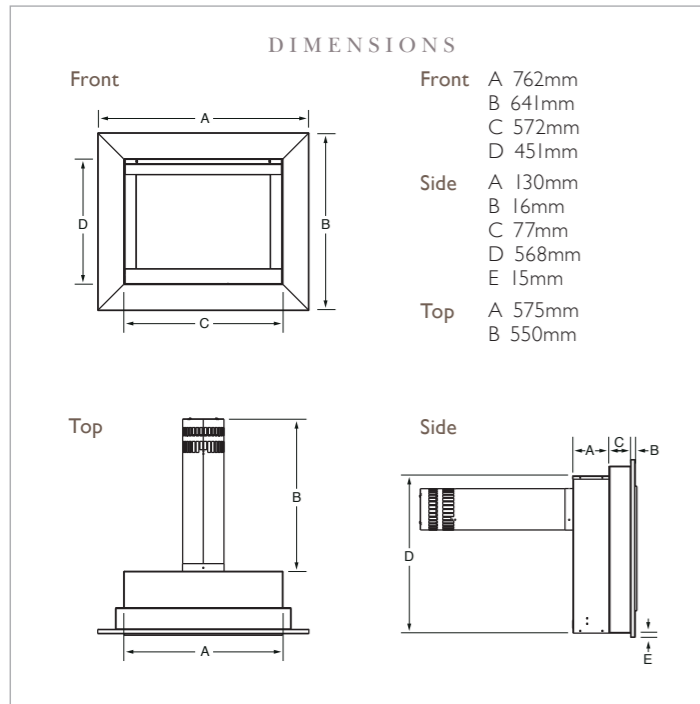

Eden Elite Slimline Balanced Flue Wall Inset
– Page 14

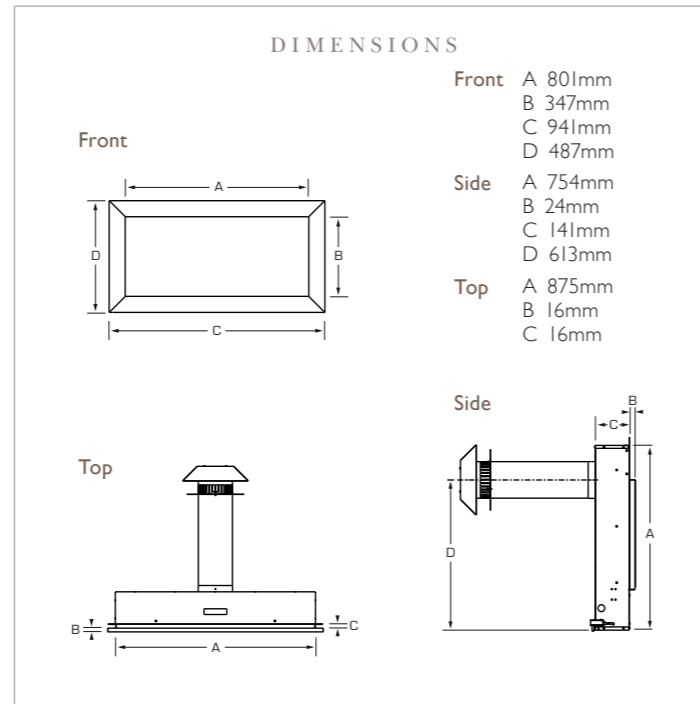

Avignon Celena Slimline Balanced Flue Suite
– Page 28

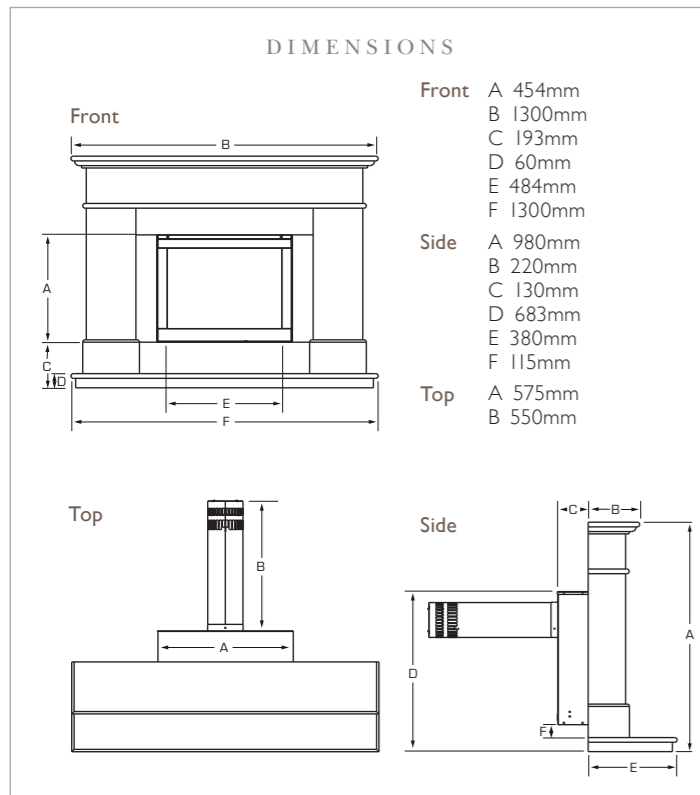

Avignon Eden Elite Slimline Balanced Flue Suite
– Page 34

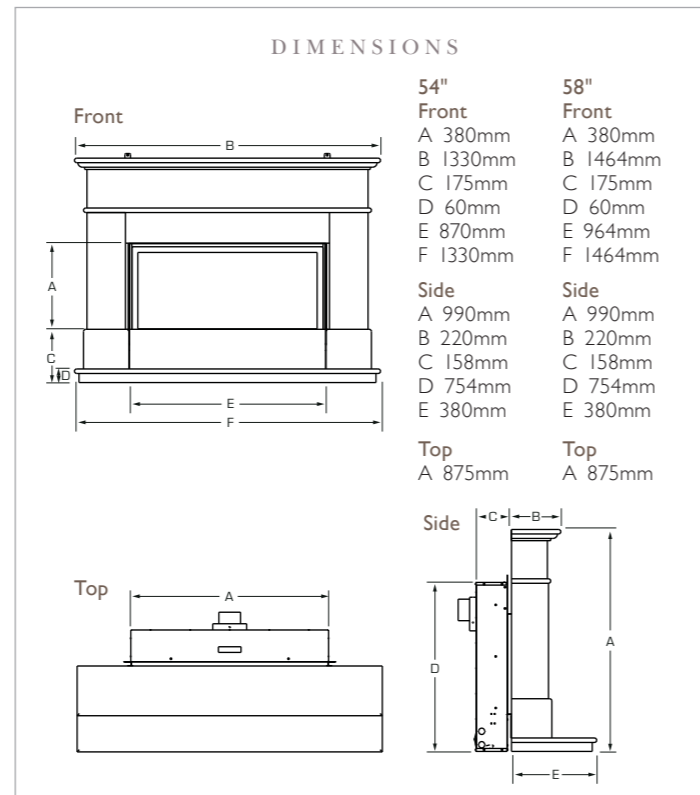

Online inspiration & information

Tap into a wealth of knowledge and discover everything you need to know about purchasing, fitting & servicing your Verine fire.

- Use our intelligent search tools to find your perfect gas fire
- Find your nearest approved Verine stockist
- Download installation and user manuals
- Register your guarantee
- Interactive updated blogs to keep you informed and intrigued

www.verinegasfires.co.uk



IMPORTANT

WARNING BFM Europe Limited is a Gas Safe Registered company. We recommend that all of our fires are installed by Gas Safe Register engineers in accordance with our instructions.

DISCLAIMER Our policy is one of constant development and improvement. We therefore reserve the right to revise designs and specifications of our products without formal notice, patents pending. We always recommend our products be viewed in an approved showroom before purchase.

Whilst we have taken every care in the preparation of this brochure it is not intended to replace the installation manual which provides more detailed information.

Photography is for illustration purposes only and although every effort has been made to ensure accurate reproduction of typical installations and flame pictures they may vary according to fire model and flue types.

We accept no liability for any loss or damage arising directly or indirectly from the use of this brochure.

We recommend that all our fires are used in conjunction with central heating and not as a primary source of heat.

In the interests of personal safety a suitable fireguard is recommended when children, the elderly and the infirm are present.

(This brochure is copyright 2018 and must not be reproduced in whole or in any part without prior written permission).