

 GAZCO

# STUDIO

GAS FIRES



# Aesthetics Performance Versatility

These are the elements that define the Studio range. Effortlessly becoming the focal point of your interior, a Studio fire brings far more than just heat to your home.

Each fire is designed to seamlessly blend beauty and performance, offering superb flame visuals and high efficiency heating. All at the touch of a button.

Presented with a variety of elegant styling options, the Studio range lets you tailor your fire to complete your home.



**Cover image:** Studio 3 Edge 'Cool Wall' with Log-effect fuel bed and EchoFlame Black Glass lining. See page 51 for further details on 'Cool Wall' kits.



We are proud to have been recognised as an award-winning manufacturer, for our high-quality products and innovative technology. Find out more at [gazco.com/awards](https://gazco.com/awards)





Studio 3, Expression frame in Graphite with Log-effect fuel bed and EchoFlame Black Glass Lining.

## Contents

Choosing your Studio fire .....	07
Studio Flue Options.....	08
Fire Types & Sizes .....	10
Fuel Effects .....	12
Frames & Surround Options .....	14
Lining Options .....	16

### Studio Cassettes

Studio 1 .....	18
Studio 2 .....	22
Studio 3 .....	26

### Studio Slimline

Studio Slimline .....	30
Studio 1 Slimline .....	32
Studio 2 Slimline .....	34
Studio Slimline Zero Clearance...	36
Studio Slimline Monaco.....	40

### Studio Duplex

Studio Duplex .....	42
---------------------	----

### Studio Freestanding

Studio Freestanding .....	44
---------------------------	----

Studio Summary and options .....	46
Technical Information .....	48

# Relax - it's a Gazco Fire...

When you choose Gazco, quality and innovative technology are assured. From traditional models to contemporary designs, Gazco is committed to creating the ultimate flame-effect gas and electric fires. Our UK research and development laboratories are amongst the most advanced in the world, ensuring that the very latest innovations are incorporated into our appliances.

Gazco is an ISO9001 and ISO14001 accredited company. Our rigorous quality control system ensures that all our appliances are safety checked and that they comply with the appropriate regulations, with all fires in this

brochure bearing both the UKCA and CE mark. Similarly, our environmental management systems ensure we work in a sustainable manner, whilst endeavouring to protect the environment by minimising any possible impact from our operations.

With over 40 years of proven experience building quality Gas fires, you can be confident that when you select a Gazco fire, you are getting the best of British design, engineering and manufacturing.



Studio 2, Steel 2 frame in Graphite with Pebble & Stone fuel bed and EchoFlame Black Glass lining.

# Expert Retailer Network

We take great care to ensure that our fires are designed, tested and manufactured to the highest possible quality and safety standards.

We are equally careful to make certain our fires are sold and installed correctly to ensure they provide you with years of enjoyment. Our products are only available from experienced, independent retailers who will be happy to show you a selection of models locally in their showrooms, often fully operational. These independent retailers will discuss your individual requirements, including both technical (such as sizing the heat output to your room and advising on your flue type) and design, to ensure that you select the most appropriate product for your home.

Our experienced retailers will also be able to advise on, or assist with, the installation process as well as help provide any after-sales support and servicing your appliance may require in the future.

Whilst we encourage our retailers to promote fireplace products and their outlets via the internet, we do not believe suitable levels of customer care and satisfaction can be obtained from purchasing the product only online and we would strongly recommend that you consider this when undertaking your research and making a purchasing decision. Furthermore, please be aware that we do not offer technical support (beyond our statutory responsibilities) for products bought via nationwide online sales, where this support would normally be offered by one of our qualified, independent retailers.

Find your local Expert Retailer

Find your nearest retailer by visiting:  
[www.gazco.com/retailers](http://www.gazco.com/retailers)



# Five Year Extended Warranty

Your Gazco Expert Retailer will provide you with a Two Year Warranty for your new gas fire. This can be extended to a Five Year Warranty by registering your fire with Gazco. Please note, these warranties exclude certain consumable parts. Fires purchased outside of Gazco's Expert Retailer Network will carry a standard 1 Year non-extendable Warranty, or minimum statutory warranty for your country. Full warranty terms and conditions are available to view at [www.gazco.com](http://www.gazco.com).



**WIN** the cost of your product back!

by registering your product online for your free extended warranty. See page 59 for more details.





6 Studio 2, Edge 'Cool Wall' with Driftwood-effect fuel bed and EchoFlame Black Glass lining. See page 51 for further details on Cool Wall kits.

# How to choose your Studio fire...

With a wealth of design options complemented by a choice of sizes, linings and fuel bed effects, these beautifully contemporary fires will add instant style and presence to any modern interior. The following pages will guide you through the wide selection of possibilities and styling options that are synonymous with the Studio range...

## 1 Step 1 Flue Options

Studio fires are available in conventional flue and balanced flue versions, allowing you to install your fire with or without a chimney.



Pages 8 - 9

## 2 Step 2 Types & Sizes

Studio fires can be selected in a variety of different types and sizes including Slimline, double-sided and even stove versions, depending on which flue type is required.



Pages 10-11

## 3 Step 3 Fuel Effects

Many Studio fires can be customised with a range of fuel effects to transform the flames, including realistic logs and stylish stone.



Pages 12-13

## 4 Step 4 Frames

Studio fires can be styled to perfectly suit your décor. Choose to install your Studio as a frameless Edge or with one of the many stylish steel and glass frames available.



Pages 14-15

## 5 Step 5 Linings

Choose the perfect lining to enhance your Studio's flames from the variety of options available. Each lining offers a backdrop for the stunning visuals.



Pages 16-17

# Studio Flue Types

Studios fires can be installed with or without a chimney, depending on the type of fire. Suitable for a wide range of homes, this versatile fire collection can be configured to suit your requirements.





# Conventional Flue



Conventional flue Studio fires are designed to use an existing brick or stone chimney, or if your home does not have a chimney, a prefabricated chimney system that can be fitted when your fire is installed.

A prefabricated chimney system creates the same circulation of heated air as a brick or stone chimney and exits the roof as a metal flue.

Conventional flue Studio fires incorporates both inset and freestanding fires.

## Key Features

1. Conventional Flue connection
2. Linerless installation with no need for additional adapters
3. Glass Fronted
4. Choice of fuel effects
5. Choice of linings
6. Choice of frame styles
7. Convected and radiant heat
8. Convected heat system outlet
9. Simple drop down door for easy maintenance access
10. Remote control included\*
11. External battery holders for ease of battery change
12. Optional mains adaptor

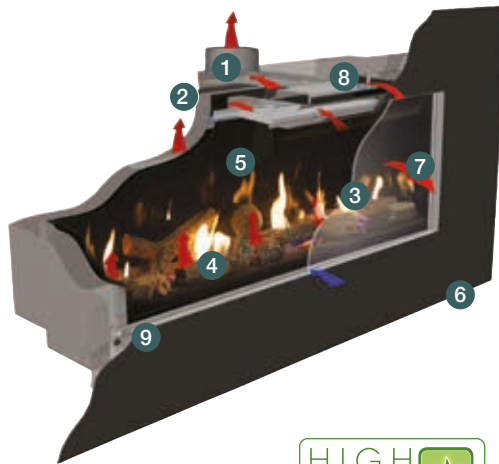

\* Illustrated below

# Balanced Flue



Balanced flue Studio fires do not require a chimney. Instead, a twin-walled pipe going from the fire to the exterior of the property draws in combustion air whilst also removing flue gases. Depending on which fire is selected, the twin-wall pipe can exit horizontally through an outside wall or vertically through the roof.

Balanced flue Studios are high efficiency glass fronted fires and are completely sealed from the room they are installed in. These include the Studio Inset and Freestanding ranges, Studio 2 Duplex and Studio Slimline range.

## Key Features

1. Balanced Flue connection
2. Variety of flueing options for location flexibility
3. Glass Fronted
4. Choice of fuel effects
5. Choice of linings
6. Choice of frame styles
7. Convected and radiant heat
8. Convected heat system outlet
9. Simple drop down door for easy maintenance access
10. External battery holders for ease of battery change
11. Programmable Thermostatic remote control included\*
12. Optional mains adaptor



\* Illustrated below

For further information on your flue and air vent requirements please see page 56.

## Programmable Thermostatic Remote Control

Studio gas fires come complete with a Programmable Thermostatic remote that also includes the additional benefits of a programmable timer and thermostatic controls, ensuring that whenever you return home, your house will always be warm and welcoming. Studio fires have an external battery which can be discretely and conveniently located up to 3 metres away from the fire. Alternatively you can choose the optional mains adaptor for an installation without batteries.



Programmable Thermostatic remote

# Studio Types & Sizes

For optimal versatility, Studio fires are available in a choice of types, sizes and heat outputs to suit a variety of interior spaces. Choose from high efficiency inset, freestanding, double sided or specially designed Slimline models for cavity wall installations.



Studio 2 Edge+ with Log-effect fuel bed and EchoFlame Black Glass lining

## Studio 1 (page 19)

The Studio 1 is the smallest fire in the range and is offered in either conventional or balanced flue models with a choice of fuel effects and linings. A freestanding stove version of this stunning fire is also available. See pages 44-45.

## Studio 2 (page 22)

The mid-sized Studio 2 offers impressive flames and heat output. Studio 2 fires come in conventional or balanced flue options with a choice of fuel effects and lining options. A freestanding stove version offers an ultra-contemporary alternative. See pages 44-45.

## Studio 3 (page 26)

Presenting a truly breath-taking view of the expansive flame visuals, the Studio 3 is the largest size in the range and can be tailored with a choice of linings and fuel effects to suit your interior.



Studio 1 Balanced flue with Pebble & Stone fuel bed & EchoFlame Black Glass lining



Studio 2 Balanced flue with Log-effect fuel bed & Black Reeded lining



Studio 3 Balanced flue with Driftwood-effect fuel bed & Black Glass lining

## Studio 1 & 2 Slimline (page 30)

The high efficiency Studio Slimline fires have been specifically designed for cavity wall installations. Offered in a choice of two sizes, they feature an ultra-slim profile whilst still providing a superb view of the flames. Available with a choice of white stones or realistic log fuel beds, these fires provide a generous heat output and are supplied complete with a Balanced Flue rear termination installation kit.



## Studio 2 Duplex (page 42)



The double-sided Studio 2 Duplex allows the flame visuals to be enjoyed from either side. Producing up to 7.9kW of heat output, this balanced flue fire has a highly realistic Log-effect fuel bed.



# Studio Fuel Effects

The fuel effects in each Studio fire are designed to create a stunning centrepiece, whether you choose the traditional ambience of the log or driftwood or the contemporary minimalism of pebbles and stones.



Studio 2, Profil frame in Anthracite with Log-effect fuel bed and EchoFlame Black Glass lining

## Log-effect



Studio fires can also be selected with the highly realistic, hand-painted Log-effect fuel bed, for a natural woodburning aesthetic that looks just like a real log fire. Tall flames jump and flow between the logs for a mesmerising focal point.

## Driftwood-effect\*



Available for inset Studio 1, 2 & 3 fires, this alternative wood-effect fuel bed creates an authentic looking driftwood composition. Presented on a bed of stones, each piece is precisely painted to resemble naturally weathered beach timber.

## Pebble & Stone\*



Ceramic pebbles positioned on a bed of stones offer an ambient beach vibe with this beautifully contemporary fuel effect for selected Studio fires. Featuring tall flames that dance across the white stones, this stylish fuel effect makes for a striking, designer statement.

## White Stones (Slimline)



Slimline Studio fires are available with a contemporary ribbon of flames on a bed of white stones, echoing the fire's clean form, these minimalist fuel effects create a designer statement that can be appreciated with or without the flames.

\*Not available to Freestanding Studio fires.

# Frame Options

Studio fires have many frame options available, including a number of different styles in steel or glass, as well as various colours and finishes. These stunning frame options have all been designed specifically to complement this contemporary fire range and offer you a spectrum of styling possibilities.



Studio 1, Glass frame with Log-effect fuel bed and EchoFlame Black Glass lining

	Studio 1	Studio 2	Studio 3	Studio Slimline	Studio Duplex
Edge	✓	✓	✓	✓	✓
Edge+	✓	✓	✓	✗	✓
Profil	✓	✓	✓	✓	✓
Expression	✓	✓	✓	✓	✓
Steel 2	✓	✓	✗	✓	✓
Glass	✓	✓	✗	✓	✓
Verve	✓	✓	✗	✓	✓
ZC Glass & Steel	✗	✗	✗	✓	✗
Monaco	✗	✗	✗	✓*	✗
Studio Freestanding Complete product	✓	✓	✗	✗	✗

\* Studio 1 Slimline only.



# Edge

Pages 6, 16, 19, 20, 24, 34, 52 & Front Cover



# Edge+

Pages 10,19, 22, 26, 28, 46



# Freestanding

Pages 17, 44, 45 & Rear Cover



# Verve

Pages 22 & 33



# Steel 2

Pages 4, 25 & 35



# Expression

Pages 3, 17, 21, 24, 27 & 32



Graphite

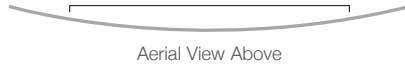

Aerial View Above

Graphite

Graphite

# Glass

Pages 14, 18, 31 & 42



Black Glass

# Profil

Pages 12, 20, 23, 26, 29, 30, 32, 35 & 43



Anthracite

# ZC Glass

Pages 37, 38 & 39



Black or White Glass front with Graphite Steel rear

# ZC Steel

Pages 36 & 38



Graphite front and rear

# Monaco

Page 41



Concrete with Black Granite top

# Lining Options

Studio gas fires are highly customisable and their choice of stylish lining options is no exception. Depending on the model, each fire can be styled to your tastes with a range of different linings that offer a dramatically different aesthetic for your fire.



Studio 2, Edge 'Cool Wall' with Log-effect fuel bed and EchoFlame Black Glass Lining. See page 51 for further details on Cool Wall kits.



Echoflame Black Glass



Black Reeded



Brick Effect

Studio 1, 2 & 3 (Inset)	✓	✓*	✗
Studio Slimline	✓	✓**	✓
Studio Duplex	✗	✓	✗
Studio Freestanding	✓	✓ (Optional)	✗

\* Excluding Studio 2 Balanced Flue | \*\* Excluding select models







Studio 1, Glass Frame with Pebble & Stone fuel bed and Black Reeded lining

# Studio 1



	Efficiency & Heat Output			Chimney or Flue Options			Gas Type		Fuel Bed			Linings		Control
	E% <sup>†</sup>	EFFICIENCY CLASS	kW	BRICK CHIMNEY	PRE-FABRICATED	BALANCED FLUE	NATURAL GAS	LPG GAS	LOGS	DRIFTWOOD	PEBBLE & STONE	BLACK REEDED	BLACK GLASS	PROGRAMMABLE THERMOSTATIC REMOTE
Studio 1 Glass Fronted Conventional Flue	72%	E	4.60kW	✓	✓	✗	✓	✓	✓	✓	✓	✓	✓	✓
Studio 1 Glass Fronted Balanced Flue	92%	A	5.30kW	✗	✗	✓	✓	✓	✓	✓	✓	✓	✓	✓

† Efficiency and heat output figures are based upon the maximum achieved in the options available. For more detailed technical information, including firebox dimensions and installation requirements, see page 48 onwards.

## Frame Options

For the complete selection of frames available with Studio fires see pages 14 - 15.

















# Studio 1 (continued)



Studio 1, Edge with Log-effect fuel bed and EchoFlame Black Glass lining



Studio 1, Profil Log-effect fuel bed and Black Reeded lining

		Efficiency & Heat Output			Chimney or Flue Options			Gas Type		Fuel Bed			Linings		Control
		 E% <sup>†</sup>	 EFFICIENCY CLASS	 kW HEAT OUTPUT	 BRICK CHIMNEY	 PRE-FABRICATED	 BALANCED FLUE	 NATURAL GAS	 LPG GAS	 LOGS	 DRIFTWOOD	 PEBBLE & STONE	 BLACK REEDED	 BLACK GLASS	 PROGRAMMABLE THERMOSTATIC REMOTE
Studio 1 Glass Fronted Conventional Flue		72%	E	4.60kW	✓	✓	✗	✓	✓	✓	✓	✓	✓	✓	✓
Studio 1 Glass Fronted Balanced Flue		92%	A	5.30kW	✗	✗	✓	✓	✓	✓	✓	✓	✓	✓	✓

† Efficiency and heat output figures are based upon the maximum achieved in the options available. For more detailed technical information, including firebox dimensions and installation requirements, see page 48 onwards.

## Frame Options

For the complete selection of frames available with Studio fires see pages 14 - 15.





Studio 1, Expression in Graphite with Driftwood-effect fuel bed and EchoFlame Black Glass lining

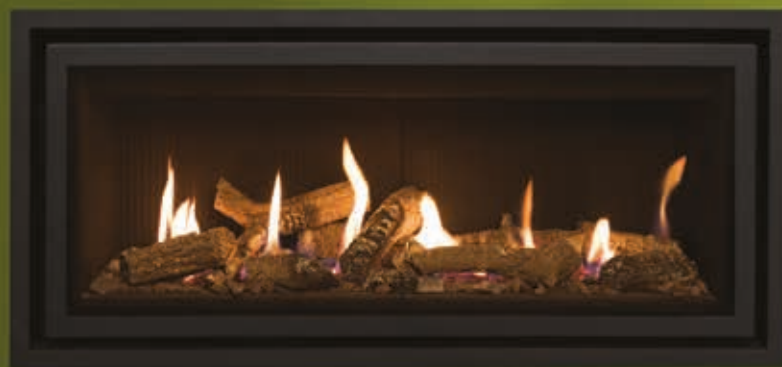

Studio 2, Edge+ with Log-effect fuel bed and Black Reeded lining



# Studio 2



Studio 2, Profil frame in Anthracite with Driftwood-effect fuel bed and EchoFlame Black Glass lining



Studio 2 Verve frame in Graphite with Pebble & Stone fuel bed and Black Reeded lining

	Efficiency & Heat Output			Chimney or Flue Options			Gas Type		Fuel Bed			Linings		Control
	E% <sup>†</sup>	EFFICIENCY CLASS	kW	BRICK CHIMNEY	PRE-FABRICATED	BALANCED FLUE	NATURAL GAS	LPG GAS	LOGS	DRIFTWOOD	PEBBLE & STONE	BLACK REEDED	BLACK GLASS	PROGRAMMABLE THERMOSTATIC REMOTE
Studio 2 Glass Fronted Conventional Flue	81%	C	6.20kW	✓	✓	✗	✓	✓	✓	✓	✓	✓	✓	✓
Studio 2 Glass Fronted Balanced Flue	92%	A	7.00kW	✗	✗	✓	✓	✓	✓	✓	✗	✓	✓	✓

<sup>†</sup> Efficiency and heat output figures are based upon the maximum achieved in the options available. For more detailed technical information, including firebox dimensions and installation requirements, see page 48 onwards.

**Frame Options**  
For the complete selection of frames available with Studio fires see pages 14 - 15.



# Studio 2 (continued)



Studio 2, Edge 'Cool Wall' with Driftwood-effect fuel bed and EchoFlame Black Glass lining.  
See page 62 for further details on Cool Wall kits.



Studio 2, Expression frame in Graphite with Pebble & Stone fuel bed and Black Reeded lining

	Efficiency & Heat Output			Chimney or Flue Options			Gas Type		Fuel Bed			Linings		Control
	E% <sup>†</sup>	EFFICIENCY CLASS	kW	BRICK CHIMNEY	PRE-FABRICATED	BALANCED FLUE	NATURAL GAS	LPG GAS	LOGS	DRIFTWOOD	PEBBLE & STONE	BLACK REEDED	BLACK GLASS	PROGRAMMABLE THERMOSTATIC REMOTE
Studio 2 Glass Fronted Conventional Flue	81%	C	6.20kW	✓	✓	✗	✓	✓	✓	✓	✓	✓	✓	✓
Studio 2 Glass Fronted Balanced Flue	92%	A	7.00kW	✗	✗	✓	✓	✓	✓	✓	✗	✓	✓	✓

<sup>†</sup> Efficiency and heat output figures are based upon the maximum achieved in the options available. For more detailed technical information, including firebox dimensions and installation requirements, see page 48 onwards.

## Frame Options

For the complete selection of frames available with Studio fires see pages 14 - 15.



Studio 2, Steel 2 frame in Graphite with Log-effect fuel bed and EchoFlame Black Glass lining



# Studio 3

Studio 3, Profil frame in Anthracite with Driftwood-effect fuel bed and EchoFlame Black Glass lining



Studio 3, Edge+ with Pebble & Stone fuel bed and EchoFlame Black Glass lining



	Efficiency & Heat Output			Chimney or Flue Options			Gas Type		Fuel Bed			Linings		Control
	E% <sup>†</sup>	EFFICIENCY CLASS	kW	BRICK CHIMNEY	PRE-FABRICATED	BALANCED FLUE	NATURAL GAS	LPG GAS	LOGS	DRIFTWOOD	PEBBLE & STONE	BLACK REEDED	BLACK GLASS	PROGRAMMABLE THERMOSTATIC REMOTE
Studio 3 Glass Fronted Balanced Flue	92%	A	8.40kW	Pg 32	Pg 32	✓	✓	✓	✓	✓	✓	✓	✓	✓

## Frame Options

For the complete selection of frames available with Studio fires see pages 14 - 15.

<sup>†</sup> Efficiency and heat output figures are based upon the maximum achieved in the options available. For more detailed technical information, including firebox dimensions and installation requirements, see page 48 onwards.





Studio 3, Expression frame in Graphite with Log-effect fuel bed and EchoFlame Black Glass lining



Studio 3, Edge+ with Log-effect fuel bed and EchoFlame Black Glass lining

# Studio 3 (continued)

Studio 3, Profil frame in Anthracite with Driftwood-effect fuel bed and EchoFlame Black Glass lining



	Efficiency & Heat Output			Chimney or Flue Options			Gas Type		Fuel Bed			Linings		Control
	E% <sup>†</sup>	EFFICIENCY CLASS	HEAT OUTPUT	BRICK CHIMNEY	PRE-FABRICATED	BALANCED FLUE	NATURAL GAS	LPG GAS	LOGS	DRIFTWOOD	PEBBLE & STONE	BLACK REEDED	BLACK GLASS	PROGRAMMABLE THERMOSTATIC REMOTE
Studio 3 Glass Fronted Balanced Flue	92%	A	8.40kW	Pg 32	Pg 32	✓	✓	✓	✓	✓	✓	✓	✓	✓

## Frame Options

For the complete selection of frames available with Studio fires see pages 14 - 15.

<sup>†</sup> Efficiency and heat output figures are based upon the maximum achieved in the options available. For more detailed technical information, including firebox dimensions and installation requirements, see page 48 onwards.



# Studio Slimline

Available in two sizes, these slimmer depth fires have been created to allow an easier, quicker and more cost effective installation option, whilst still retaining all the unmistakable characteristics of the Gazco Studio range.



Studio 2 Slimline Balanced Flue, Profil frame in Graphite with Log-effect fuel bed and EchoFlame Black Glass Lining

## A Slimline fire for cavity wall installation

Studio Slimline fires have been specifically developed to allow the highly desirable aesthetics of a landscape format to be achieved in a wider variety of homes by simply recessing into the internal leaf of a cavity wall. Available in two sizes, both come complete with a dedicated rear exit balanced flue termination kit for easy installation - see page 56 for further information. For even more installation possibilities the Monaco surround (see page 40) allows for mounting on to a flat external wall and the Zero Clearance range allows you to install Slimline fires in walls constructed from conventional materials such as studwork and plasterboard (see page 36).

Although compact in design, these highly efficient fires have a generous heat output which is easily controlled with the Programmable Thermostatic remote control.

## Key Features

1. Shallow firebox depth of just 155mm
2. Balanced Flue connection
3. Choice of linings
4. Choice of contemporary or realistic fuel effects
5. Choice of frame styles
6. Convected and radiant heat
7. Convected heat system outlet
8. Programmable Thermostatic remote control
9. Rear exit Balanced Flue Termination Kit included\*
10. External battery holder for ease of battery change\*
11. Optional mains adaptor\*

\* Not illustrated



## Slimline Frame Options

Studio Slimline fires can be styled to your interior with the one of the many high quality frames available, a selection of which are shown on these pages and overleaf. Alternatively, for a minimalist look, the frameless Edge design allows for a striking, hole-in-the-wall installation. For a complete frame style reference please see pages 14-15.

## Fuel Effects and Lining Options

To further extend your options for personalisation, there is a choice of linings and fuel effects available for the Studio Slimline fires. Each of the lining choices, including timeless Black Reeded, classic Brick-effect or depth-enhancing EchoFlame Black Glass can be paired with either realistic logs or contemporary white stone fuel effects.



Black Reeded Lining



Brick-effect Lining



EchoFlame Black Glass Lining

With each combination offering a significantly different appearance to the fire, you can be sure to select the perfect combination of fuel effect, lining and frame style to suit your interior decor.



Studio 1 Slimline Balanced Flue, Glass frame with White Stone fuel bed & Black Reeded Lining.

# Studio 1 Slimline



Studio 1 Slimline Balanced Flue, Expression frame in Graphite with Log-effect fuel bed and EchoFlame Black Glass Lining



Studio 1 Slimline Balanced Flue, Profil frame in Anthracite with White Stone fuel bed and Black Reeded Lining

	Efficiency & Heat Output†			Chimney or Flue Options			Gas Type		Fuel Bed		Linings			Control
	E%	ENERGY EFFICIENCY CLASS	kW	BRICK CHIMNEY	PRE-FABRICATED	BALANCED FLUE	NATURAL GAS	LPG GAS	LOGS	WHITE STONES**	BRICK EFFECT*	BLACK REEDED*	BLACK GLASS	PROGRAMMABLE THERMOSTATIC REMOTE
Studio 1 Slimline Balanced Flue	82%	C	3.80kW	X	X	✓	✓	✓	✓	✓	✓	✓	✓	✓

† Efficiency and heat output figures are based upon the maximum achieved in the options available. For more detailed technical information, including firebox dimensions and installation requirements, see page 48 onwards.

\* For LPG models, lining set can be purchased separately | \*\* Natural Gas models only

## Frame Options

For the complete selection of frames available with Studio fires please see pages 14 - 15.





Studio 1 Slimline Balanced Flue, Verve Frame in Graphite with Log-effect fuel bed and Brick-effect Lining



Studio 2 Slimline Balanced Flue, Edge with Log-effect fuel bed and EchoFlame Black Glass Lining

# Studio 2 Slimline



Studio 2 Slimline Balanced Flue, Steel 2 Frame in Graphite with Log-effect fuel bed and Brick-effect Lining



Studio 2 Slimline Balanced Flue, Profil Frame in Anthracite with Log-effect fuel bed and EchoFlame Black Glass Lining

	Efficiency & Heat Output†			Chimney or Flue Options			Gas Type		Fuel Bed		Linings			Control
	E%	ENERGY EFFICIENCY CLASS	kW	BRICK CHIMNEY	PRE-FABRICATED	BALANCED FLUE	NATURAL GAS	LPG GAS	LOGS	WHITE STONES	BRICK EFFECT*	BLACK REEDED*	BLACK GLASS	PROGRAMMABLE THERMOSTATIC REMOTE
Studio 2 Slimline Balanced Flue	82%	C	5.00kW	X	X	✓	✓	✓	✓	✓	✓	✓	✓	✓

† Efficiency and heat output figures are based upon the maximum achieved in the options available. For more detailed technical information, including firebox dimensions and installation requirements, see page 48 onwards.

\* For LPG models, lining set can be purchased separately.

**Frame Options**  
 For the complete selection of frames available with Studio fires please see pages 14 - 15.



# Studio Slimline Zero Clearance Range

Studio 1 Slimline Balanced Flue, ZC Steel frame in Graphite with Log-effect fuel bed and Black Reeded Lining



Studio Slimline Zero Clearance frame kits increase your installation possibilities around the home by allowing for simpler and easier fitting of Slimline fires into existing walls.

Unlike many gas fires, the Slimline Zero Clearance range does not need a specially constructed non-combustible wall to house the appliance. The Zero Clearance Frame kit includes an enclosure that houses the fire and circulates air around the appliance, reducing the heat transferred to the installation wall by directing it back into the room.

This means you can choose to fit your Slimline fire into walls with standard plasterboard and stud-work thanks to the Zero Clearance kit's ability to keep wall temperatures to a minimum. Zero Clearance Slimline fires are available in both Studio 1 and 2 Sizes

## Key Features

1. Zero clearance box enclosure to reduce wall temperatures (included with frame)
2. Shallow firebox depth of just 155mm
3. Balanced flue connection
4. Choice of linings
5. Choice of contemporary or realistic fuel effects
6. Choice of new Zero clearance box frame styles
7. Convected and radiant heat system
8. Convected heat system outlet
9. Programmable Thermostatic remote control
10. Rear exit balanced flue termination kit included\*
11. External battery holder for ease of battery change\*
12. Optional mains adaptor\*

\* Not illustrated





Studio 2 Slimline Balanced Flue, ZC Glass frame in Black Glass with Log-effect fuel bed and EchoFlame Black Glass lining

# Studio Slimline Zero Clearance Range (continued)



Studio 2 Slimline Balanced Flue, ZC Steel frame in Graphite with Log-effect fuel bed and EchoFlame Black Glass Lining



Studio 1 Slimline Balance Flue, ZC Glass frame in White Glass with Log-effect fuel bed and Brick-effect Lining

Slimline Zero Clearance Frames offer unique, eye-catching and functional styling options. Cleverly designed to not only enhance the look of your fire, each frame also allows cool air to be drawn from the room and around the Zero Clearance enclosure. The air is then heated and convected back into the room, reducing the surrounding wall temperatures.

Frame options are available in two specifically designed frame styles exclusive to the Zero Clearance Slimline range. Choose from ZC Steel in a Graphite finish or ZC Glass in a choice of either White Glass\* or Black Glass, both providing an exceptional finish that completely covers the fire's installation edge whilst creating a stylish focal point.

\* ZC White Glass Frame available for Studio 1 Slimline only



Studio 2 Slimline Balanced Flue, ZC Glass frame in Black Glass with Log-effect fuel bed and Brick-effect Lining



# Studio Slimline Monaco Surround

Creating a stunning, contemporary centrepiece in your home, the Monaco surround for the Studio Slimline 1 is specifically designed for mounting the fire to a flat external wall and makes a statement wherever it is located. The Monaco's neat design means you can add the Slimline 1 fire to your living area without having to create a cavity in an existing wall, ensuring no additional building work is required to install the fire.

Thanks to its versatile design, the Monaco lets you tailor your fire surround to suit your tastes. With its modular construction, the surround can be assembled with the Slimline 1 fire positioned centrally or offset to the left or right. For added presence, you can increase the height either above or below the fire by adding an optional surround extension piece - letting you choose exactly how your Slimline Monaco will look in your home.

Offering further styling possibilities, the Monaco is supplied in a stunning unfinished concrete for minimalist elegance but can be easily painted with water based paints to suit your interior. Featuring a recessed storage plinth, the surround can also be visually enhanced with pre-cut logs for the natural feel of a woodburning fire.

## Key Features and Possible Configurations



1. Glass reinforced concrete surround
2. Choice of central or offset fire positioning
3. Black Granite top†
4. Integrated storage plinth
5. Shallow firebox depth of just 155mm
6. Balanced flue connection
7. Choice of linings
8. Choice of contemporary or realistic fuel effects
9. Convected and radiant heat system
10. Convected heat system outlet
11. Programmable Thermostatic remote control
12. Optional extension piece\*
13. Rear exit balanced flue termination kit included\*
14. External battery holder for ease of battery change\*
15. Optional mains adaptor\*

\* Not illustrated



Monaco with left aligned fire



Monaco with right aligned fire



Monaco with extension above centrally aligned fire



Monaco with extension below right aligned fire



Monaco with extension above left aligned fire

Δ Dimensions given are those overall visible upon installation. For more detailed technical information, including firebox dimensions and installation requirements, please see page 48 onwards.

† Granite is a naturally occurring material and may exhibit subtle variations in colour and shade. The Black Granite top will become hot during use and is therefore unsuitable for placing objects on or using as a mantel.

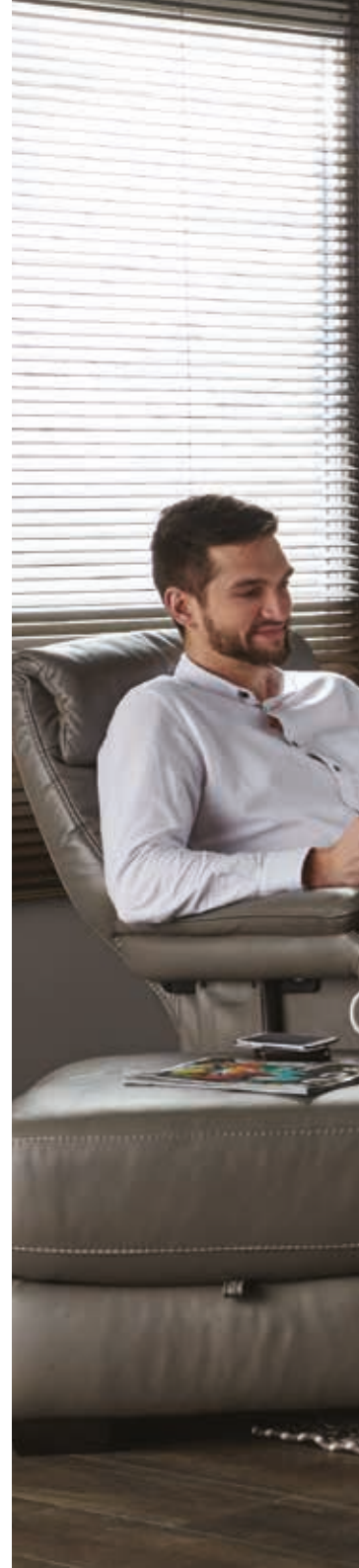







# Studio Duplex

For a truly awe-inspiring focal point in your home, the high efficiency, double-sided Duplex fire offers the ultimate solution to stylish dual space heating.



Studio 2 Duplex Balanced Flue, Glass frame with Log-effect fuel bed and Black Reeded lining



Studio 2 Duplex Balanced Flue, Profil frame in Anthracite with log-effect fuel bed and Black Reeded lining

	Efficiency & Heat Output†			Chimney or Flue Options			Gas Type		Fuel Bed	Lining	Control
	E%	ENERGY EFFICIENCY CLASS	kW	BRICK CHIMNEY	PRE-FABRICATED	BALANCED FLUE	NATURAL GAS	LPG GAS	LOGS	BLACK REEDED	PROGRAMMABLE THERMOSTATIC REMOTE
Studio 2 Duplex Balanced Flue	92%	A	7.90kW	X	X	✓	✓	X	✓	✓	✓

† Efficiency and heat output figures are based upon the maximum achieved in the options available. For more detailed technical information, including firebox dimensions and installation requirements, see page 48 onwards.

The Studio 2 Duplex offers the unique installation possibility of locating the fire between two separate living areas, allowing the stunning flames and 7.9kW heat output to be appreciated from both sides.

### Frame Options

The Studio 2 Duplex has the benefit of dual styling possibilities, allowing you to select a different look for either side of the fire. For the complete selection of frames available with Studio fires see pages 14 - 15.

See additional image on page 52.

# Studio Freestanding

Studio Freestanding models present superb flames in an ultra-modern, landscape stove form that can be styled with a matching plinth or bench to suit your interior tastes.



Studio 2 Freestanding on Plinth with Log-effect fuel bed and EchoFlame Black Glass lining





Studio 2 Freestanding on Bench with Log-effect fuel bed and EchoFlame Black Glass lining.



Studio 1 Freestanding on Plinth with Log-effect fuel bed and Optional Black Reeded lining.

	Efficiency & Heat Output			Chimney or Flue Options			Gas Type		Fuel Bed	Linings		Control
	E% <sup>†</sup>	EFFICIENCY CLASS	HEAT OUTPUT kW	BRICK CHIMNEY	PRE-FABRICATED	BALANCED FLUE	NATURAL GAS	LPG GAS	LOGS	BLACK GLASS	BLACK REEDED	PROGRAMMABLE THERMOSTATIC REMOTE
Studio 1 Freestanding Conventional Flue	72%	E	4.60kW	✓	✓	✗	✓	✓	✓	✓	✓*	✓
Studio 1 Freestanding Balanced Flue	92%	A	5.30kW	✗	✗	✓	✓	✓	✓	✓	✓*	✓
Studio 2 Freestanding Conventional Flue	81%	C	6.20kW	✓	✓	✗	✓	✓	✓	✓	✓*	✓
Studio 2 Freestanding Balanced Flue	92%	A	7.00kW	✗	✗	✓	✓	✓	✓	✓	✗	✓

† Efficiency and heat output figures are based upon the maximum achieved in the options available. For more detailed technical information, including firebox dimensions and installation requirements, see page 48 onwards.

\* Optional Linings

## Mounting Options

Studio Freestanding fires can be selected with a curved Plinth or Bench mount in a matching black finish for Studio 1 Freestanding fires or a choice of either matching white or black finishes for Studio 2 Freestanding fires.

See additional image on rear cover.

# Summary & Options

Diverse and versatile, the Studio fire range offers numerous possibilities from stylish frames and lining options to installations without a chimney. The table opposite shows the various options available for each Studio fire.



	Inset Studio Fires					Studio Slimline		Studio 2 Duplex	Studio Freestanding			
												
	Studio 1 CF	Studio 1 BF	Studio 2 CF	Studio 2 BF	Studio 3 BF	Slimline 1 BF	Slimline 2 BF	Studio 2 Duplex BF	Freestanding 1 CF	Freestanding 1 BF	Freestanding 2 CF	Freestanding 2 BF
Log-effect	✓	✓	✓	✓	✓	✓	✓	✓	✓	✓	✓	✓
Driftwood-effect	✓	✓	✓	✓	✓	X	X	X	X	X	X	X
Pebble & Stone	✓	✓	✓	✓	✓	X	X	X	X	X	X	X
White Stone	X	X	X	X	X	✓	✓	X	X	X	X	X
<b>Installation Type:</b>												
Hearth Mounted Installation	X	X	X	X	X	X	X	X	✓	✓	✓	✓
Wall Installation	✓	✓	✓	✓	✓	✓	✓	✓	X	X	X	X
Cavity Wall Specific Fire	X	X	X	X	X	✓	✓	X	X	X	X	X
Double Sided Fire	X	X	X	X	X	X	X	✓	X	X	X	X
<b>Key Features:</b>												
Remote Control	✓	✓	✓	✓	✓	✓	✓	✓	✓	✓	✓	✓
Timer and Thermostat Programmable	✓	✓	✓	✓	✓	✓	✓	✓	✓	✓	✓	✓
Glass Fronted High Efficiency	✓	✓	✓	✓	✓	✓	✓	✓	✓	✓	✓	✓
Natural Gas or LPG	✓	✓	✓	✓	✓	✓	✓	✓ <sup>†</sup>	✓	✓	✓	✓
Choice of Linings	✓	✓	✓	X	✓	✓	✓	X	✓	✓	✓	X
Wide Selection of Frames	✓	✓	✓	✓	✓	✓	✓	✓	X	X	X	X
Frameless 'Edge' Option	✓	✓	✓	✓	✓	✓	✓	✓	X	X	X	X
Conventional Flue ODS safety device*	✓	n/a	✓	n/a	n/a	n/a	n/a	n/a	✓	n/a	✓	n/a
Balanced Flue Firebox Relief Venting System <sup>Δ</sup>	n/a	✓	n/a	✓	✓	✓	✓	✓	n/a	✓	n/a	✓
Additional air vent required	X	X	✓	X	X	X	X	X	X	X	✓	X
Conventional Flue	✓	X	✓	X	X	X	X	X	✓	X	✓	X
Balanced Flue	X	✓	X	✓	✓	✓	✓	✓	X	✓	X	✓
Maximum Heat Output	4.60kW	5.30kW	6.20kW	7.00kW	8.40kW	4.25kW	5.00kW	7.90kW	4.60kW	5.30kW	6.20kW	7.00kW
Efficiency Class	E	A	C	A	A	C	C	A	E	A	C	A
Maximum Efficiency	72%	92%	81%	92%	92%	82%	82%	92%	72%	92%	81%	92%

\* ODS (Oxygen Depletion Sensor) - This Conventional Flue safety feature will shut off the gas supply to the burner in the event of a reduction to oxygen levels in the room. Δ All Gazco Balanced Flue fires have relief vents in the firebox ensuring compliance with EN 613:2001 for delayed ignition safety standards.

<sup>†</sup> Only Natural Gas model available



# Technical Information

The following pages provide the dimensional, heat input/output, efficiency and product code information you will need to choose your new Gazco fire. For more detailed specifications, please consult your Gazco retailer. Complete installation instructions may be downloaded from [www.gazco.com](http://www.gazco.com).

## Studio 1 Glass Fronted Gas Fire information

Supplied with Programmable Thermostatic remote control

- ▼ Choose your fire, fuel effect and lining set from the options below  
(framing options can be found on page 61)

### STEP 1 : FIRE CHOICE

		Heat Input	Heat Output	Efficiency	Efficiency Class
⊗ 123-007	Studio 1 Conventional Flue Natural Gas	6.30kW	4.10kW	72%	E
⊗ 123-603	Studio 1 Conventional Flue LPG	6.90kW	4.60kW	72%	E
⊗ 123-024	Studio 1 Balanced Flue Natural Gas	6.30kW	5.20kW	92%	A
⊗ 123-629	Studio 1 Balanced Flue LPG	6.30kW	5.30kW	92%	A

### STEP 2 : FUEL EFFECT

CE1839	Studio 1 Log Set
923-632	Studio 1 Pebble & Stone Set †
923-019	Studio 1 Driftwood Set †

### STEP 3 : LINING SETS

923-517	Studio 1 Conventional Flue - Black Reeded Lining Set
923-240	Studio 1 Conventional Flue - Black Glass Lining Set
923-607	Studio 1 Balanced Flue - Black Reeded Lining Set
923-282	Studio 1 Balanced Flue - Black Glass Lining Set

## Studio 2 Glass Fronted Gas Fire information

Supplied with Programmable Thermostatic remote control

- ▼ Choose your fire, fuel effect and lining set from the options below  
(framing options can be found on page 61)

### STEP 1 : FIRE CHOICE

		Heat Input	Heat Output	Efficiency	Efficiency Class
⊗ 123-012	Studio 2 Conventional Flue Natural Gas	8.50kW	6.20kW	81%	C
⊗ 123-611	Studio 2 Conventional Flue LPG	8.50kW	6.20kW	81%	C
⊗ 123-030	Studio 2 Balanced Flue Natural Gas	8.50kW	7.00kW	92%	A
⊗ 123-653	Studio 2 Balanced Flue LPG	8.00kW	6.80kW	92%	A

### STEP 2 : FUEL EFFECT

CE1840	Studio 2 Log Set
923-665	Studio 2 Pebble & Stone Set †
923-037	Studio 2 Driftwood Set †

### STEP 3 : LINING SETS

923-744	Studio 2 Conventional Flue - Black Reeded Lining Set
923-267	Studio 2 Conventional Flue - Black Glass Lining Set
923-294	Studio 2 Balanced Flue - Black Glass Lining Set

† Available to Inset Studio fires only

# Studio 3 Glass Fronted Gas Fire information

Supplied with Programmable Thermostatic remote control

▼ Choose your fire, fuel effect and lining set from the options below

(framing options can be found on page 61)

## STEP 1 : FIRE CHOICE

		Heat Input	Heat Output	Efficiency	Efficiency Class	
☒	123-043	Studio 3 Balanced Flue Natural Gas	10.10kW	8.40kW	92%	A
☒	123-666	Studio 3 Balanced Flue LPG	10.50kW	8.90kW	92%	A

## STEP 2 : FUEL EFFECT

CE1770	Studio 3 Log Set
923-686	Studio 3 Pebble & Stone Set
923-121	Studio 3 Driftwood Set

## STEP 3 : LINING SETS

923-381	Studio 3 Balanced flue - Black Reeded Lining Set
923-365	Studio 3 Balanced flue - Black Glass Lining Set

## Additional Information

### Conventional Flue Installation

The conventionally flued Glass Fronted Studio has been designed with ease of installation in mind and can be installed two ways:

- 1) Direct connection to a 5" flue liner or 5" twin wall gas vent system
- 2) No additional fluing is needed when it is installed into an existing builders opening below a masonry chimney and sealed to the fireplace opening (assuming that the chimney is of sound construction).

### Glass Fronted, Conventional Flue Studio Dimensions (mm)

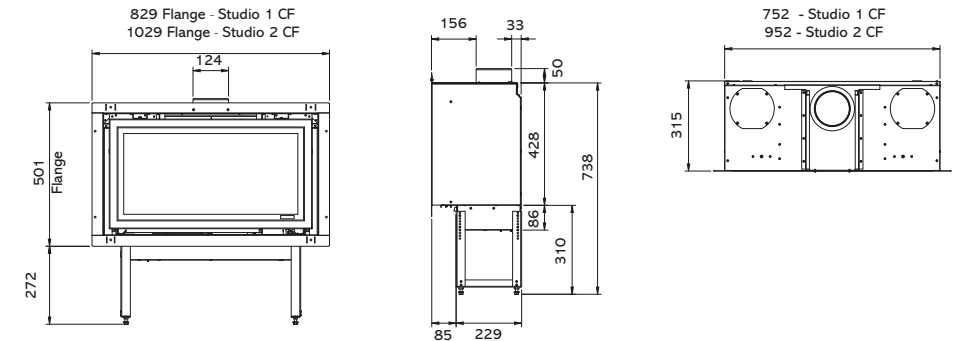

### Glass Fronted, Balanced Flue\* Studio Dimensions (mm)

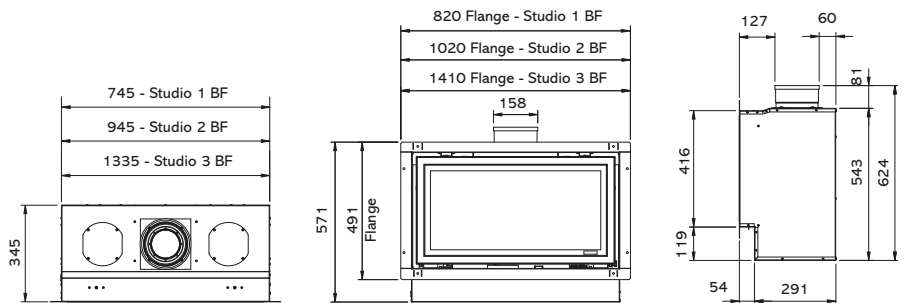

\* For more Balanced Flue information and options please refer to our Concentric Flue System brochure which can be viewed or downloaded online at [www.gazco.com](http://www.gazco.com)

# Studio 1, 2 & 3 Frame Information

Description	Frame Finish	Glass Fronted CF Product Code	Frame Size (mm)			Glass Fronted BF Product Code	Frame Size (mm)		
			w	h	d		w	h	d
<b>STUDIO 1</b>									
Profil	Anthracite	<b>8710CFANO1</b>	846	520	13	<b>8710BFANO1</b>	836	510	13
Steel 2	Graphite	<b>923-883</b>	1264	528	27	<b>923-883</b>	1264	528	27
Expression	Graphite	<b>923-546</b>	950	624	40	<b>923-656</b>	940	614	40
Verve	Graphite	<b>923-300</b>	1264	528	53	<b>923-300</b>	1264	528	53
Glass	Black Glass	<b>923-628</b>	1264	528	29	<b>923-628</b>	1264	528	29
Edge+*	Black	<b>923-006</b>	788	464	43	<b>923-025</b>	778	454	43

<b>STUDIO 2</b>									
Profil	Anthracite	<b>8717CFANO2</b>	1046	520	13	<b>8717BFANO2</b>	1036	510	13
Steel 2	Graphite	<b>923-556</b>	1500	528	27	<b>923-556</b>	1500	528	27
Expression	Graphite	<b>923-574</b>	1150	624	40	<b>923-709</b>	1140	614	40
Verve	Graphite	<b>923-514</b>	1500	528	53	<b>923-514</b>	1500	528	53
Glass	Black Glass	<b>923-535</b>	1500	528	29	<b>923-535</b>	1500	528	29
Edge+*	Black	<b>923-017</b>	988	464	43	<b>923-028</b>	978	454	43

<b>STUDIO 3</b>									
Profil	Anthracite	-	N/A	N/A	N/A	<b>8720BFANO3</b>	1426	510	13
Expression	Graphite	-	N/A	N/A	N/A	<b>923-753</b>	1530	614	40
Verve	Graphite	-	N/A	N/A	N/A	-	N/A	N/A	N/A
Glass	Black Glass	-	N/A	N/A	N/A	-	N/A	N/A	N/A
Edge+*	Black	-	N/A	N/A	N/A	<b>923-040</b>	1368	454	43

\*When choosing an Edge+ frame an Edge kit is also required for installation.

The above information is to assist you in your choice of a suitable Gazco fire. This is not intended to be all the information required to install your fire. This can be obtained from your local Gazco retailer or you can download the full installation instructions from the Gazco website at [www.gazco.com](http://www.gazco.com)



# Studio 1, 2 & 3 Options & Accessories

## GLASS FRONTED STUDIO FIRES

Product Code	Description
<b>8572</b>	Warm air ducting kit (2 outlets)
<b>8524</b>	Balanced flue kit - vertical †
<b>999-620</b>	Remote system mains adaptor
<b>STUDIO 1</b>	
<b>8727CFEK01</b>	Edge fitting kit for conventional flue
<b>8727BFEK01</b>	Edge fitting kit for balanced flue †
<b>8727CFCW01</b>	Cool Wall fitting kit for conventional flue
<b>8727BFCW01</b>	Cool Wall fitting kit for balanced flue †
<b>8534</b>	Balanced flue kit - up and out †
<b>923-517</b>	Black Reeded lining set for conventional flue
<b>923-607</b>	Black Reeded lining set for balanced flue
<b>923-240</b>	Black Glass lining set for conventional flue
<b>923-282</b>	Black Glass lining set for balanced flue
<b>STUDIO 2</b>	
<b>8727CFEK02</b>	Edge fitting kit for conventional flue
<b>8727BFEK02</b>	Edge fitting kit for balanced flue †
<b>8727CFCW02</b>	Cool Wall fitting kit for conventional flue
<b>8727BFCW02</b>	Cool Wall fitting kit for balanced flue †
<b>8509</b>	Balanced flue kit - up and out †
<b>923-744</b>	Black Reeded lining set for conventional flue
<b>923-267</b>	Black Glass lining set for conventional flue
<b>923-294</b>	Black Glass lining set for balanced flue
<b>STUDIO 3</b>	
<b>8727BFEK03</b>	Edge fitting kit for balanced flue †
<b>8727BFCW03</b>	Cool Wall fitting kit for balanced flue †
<b>8567</b>	Balanced flue kit - up and out †
<b>923-381</b>	Black Reeded lining set for balanced flue
<b>923-365</b>	Black Glass lining set for balanced flue

† For more Balanced Flue information and options please refer to our Concentric Flue System brochure which can be viewed or downloaded online at [www.gazco.com](http://www.gazco.com)

# Studio Edge & Cool Wall Kits

Available for Glass Fronted Studio fires

## Edge Kit

This kit is screw-mounted to the front flange of the outer firebox. The L-shaped attachments can either provide a 20mm return against which high temperature plasterboard/screed can be butted up for the 'clean edge' look or, if the firebox flange is on the outside of a brick or studwork wall, allow ceramic or stone tiles to be fixed with a similar look. The Edge Kit is finished in black to complement the Studio and is perfect for installations on tiled walls or using stone slips. For a seamless Edge installation on a plastered wall it we suggest using the below 'Cool Wall' kit.

## Cool Wall Kit

Again, screw-mounted to the front flange of the outer firebox, the 60mm deep U-shaped attachments of the Cool Wall kit are designed primarily for studwork false chimney breasts. The additional depth allows some of the heat to be vented up into the void above the firebox and then re-enter the room at a higher level. The effect is to produce a cooler wall immediately above the appliance than would otherwise be the case. The Cool Wall Kit is left unfinished so that it can be painted to match the front face of your fireplace.

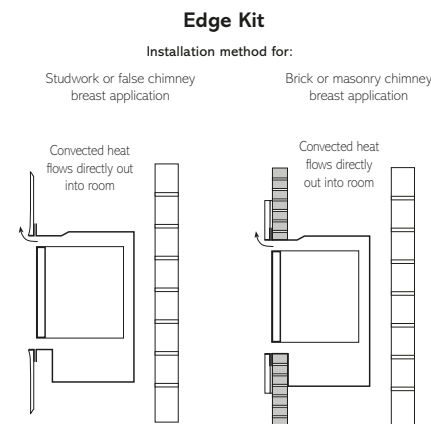

When using the Edge Kit the fire is recessed by 20mm from the finished wall surface and the kit is finished in black to complement the Studio.

**NB:** When using the Edge Kit, heat resistant board and high temperature finishing plaster must be used. Please refer to installation instructions for full details.

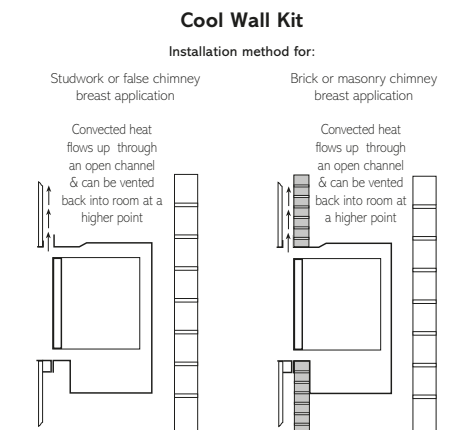

When using the Cool Wall Kit the fire is recessed by 60mm from the finished wall surface and the kit is left unfinished so that it can be painted to match your decor.

**NB:** Full installation information, including the requirement for the use of non-combustible materials, can be downloaded from [www.gazco.com](http://www.gazco.com)

# Studio 2 Duplex Fires

## FIRE INFORMATION

Product Code	Flue Type	Gas Type	Fuel Effect	Heat Input	Heat Output	Efficiency	Efficiency Class	Lining
⊗ 123-329	Balanced flue	Nat. Gas	Logs	9.6kW	7.9kW	92%	A	Black Reeded

## STUDIO 2 DUPLEX DIMENSIONS (mm)

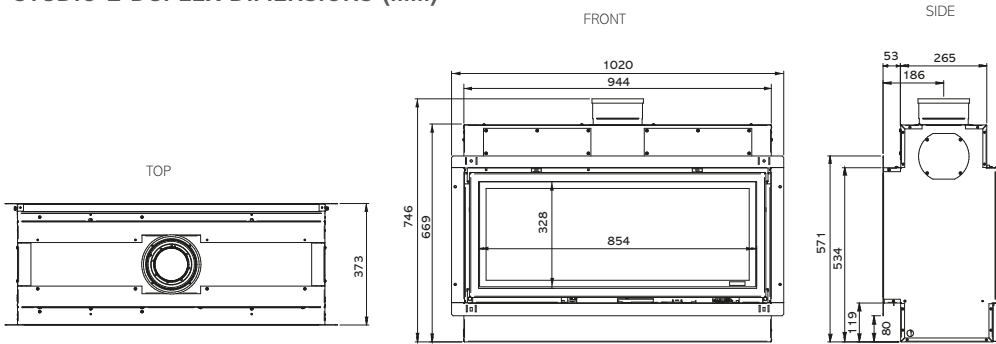

## FRAME INFORMATION

Description	Frame Finish	Product Code	Frame Size (mm)		
			w	h	d
Profil	Anthracite	8717BFAN02	1036	510	13
Steel 2	Graphite	923-556	1500	528	30
Expression	Graphite	923-709	1140	614	40
Verve	Graphite	923-514	1500	528	56
Glass	Black Glass	923-535	1500	528	33.5
Edge+	Black	923-028	978	454	43

## STUDIO 2 DUPLEX OPTIONS

Product Code	Description
8727BFEK02	Edge fitting kit for BF †
8727BFCW02	Cool Wall fitting kit for BF †
8572	Warm air ducting kit (2 outlets)
923-696	Duplex - Black Reed Lining Set
8567	Balanced flue kit - up and out †
8524	Balanced flue kit - vertical †
999-201	Horizontal Exit terminal guard (required for below 2m) †
999-620	Remote system mains adaptor

† For more Balanced Flue information and options please refer to our Concentric Flue System brochure which can be viewed or downloaded online at [www.gazco.com](http://www.gazco.com)

The above information is to assist you in your choice of a suitable Gazco fire. This is not intended to be all the information required to install your fire. This can be obtained from your local Gazco retailer or you can download the full installation instructions from the Gazco website at [www.gazco.com](http://www.gazco.com)



Studio 2 Duplex Balanced Flue, Edge 'Cool Wall' with log-effect fuel bed and Black Reeded lining. See page 51 for further details on Cool Wall kits.

# Studio 1 & 2 Slimline Fires

## STUDIO 1 SLIMLINE FIRE INFORMATION

Product Code	Description	Flue Type	Gas Type	Fuel Effect	Heat Input	Heat Output	Efficiency	Efficiency Class	Lining
⊗ <b>123-169</b>	Studio 1 Slimline	Balanced	Nat. Gas	Logs	5.2kW	3.8kW	82%	C	Black Reeded
⊗ <b>123-375</b>	Studio 1 Slimline	Balanced	Nat. Gas	White Stones	5.2kW	3.8kW	82%	C	Black Reeded
⊗ <b>123-353</b>	Studio 1 Slimline	Balanced	Nat. Gas	Logs	5.2kW	3.8kW	82%	C	Brick-effect
⊗ <b>123-266</b>	Studio 1 Slimline	Balanced	Nat. Gas	White Stones	5.2kW	3.8kW	82%	C	Brick-effect
⊗ <b>123-143</b>	Studio 1 Slimline	Balanced	Nat. Gas	Logs	5.2kW	3.8kW	82%	C	Black Glass
⊗ <b>123-623</b>	Studio 1 Slimline	Balanced	LPG	Logs	5.1kW	3.8kW	82%	C	Black Glass
⊗ <b>123-223</b>	Studio 1 Slimline	Balanced	Nat. Gas	White Stones	5.2kW	3.8kW	82%	C	Black Glass

## STUDIO 2 SLIMLINE FIRE INFORMATION

Product Code	Description	Flue Type	Gas Type	Fuel Effect	Heat Input	Heat Output	Efficiency	Remote Control	Lining
⊗ <b>123-321</b>	Studio 2 Slimline	Balanced	Nat. Gas	Logs	6.1kW	4.5kW	82%	C	Black Reeded
⊗ <b>123-027</b>	Studio 2 Slimline	Balanced	Nat. Gas	White Stones	6.1kW	4.5kW	82%	C	Black Reeded
⊗ <b>123-396</b>	Studio 2 Slimline	Balanced	Nat. Gas	Logs	6.1kW	4.5kW	82%	C	Brick-effect
⊗ <b>123-110</b>	Studio 2 Slimline	Balanced	Nat. Gas	White Stones	6.1kW	4.5kW	82%	C	Brick-effect
⊗ <b>123-102</b>	Studio 2 Slimline	Balanced	Nat. Gas	Logs	6.1kW	4.5kW	82%	C	Black Glass
⊗ <b>123-545</b>	Studio 2 Slimline	Balanced	LPG	Logs	6.6kW	5.0kW	82%	C	Black Glass
⊗ <b>123-117</b>	Studio 2 Slimline	Balanced	Nat. Gas	White Stones	6.1kW	4.5kW	82%	C	Black Glass
⊗ <b>123-571</b>	Studio 2 Slimline	Balanced	LPG	White Stones	6.6kW	5.0kW	82%	C	Black Glass

## STUDIO 1 SLIMLINE FRAME INFORMATION

Frame	Frame Finish	Product Code	Frame Size (mm)		
			w	h	d
Profil	Anthracite	<b>8710BFANO1</b>	836	510	13
Steel 2	Graphite	<b>923-883</b>	1264	528	30
Expression	Graphite	<b>923-656</b>	940	614	40
Verve	Graphite	<b>923-300</b>	1264	528	56
Glass	Black Glass	<b>923-628</b>	1264	528	33.5
ZC Steel**	Graphite	<b>923-715</b>	940	615	27
ZC Glass**	Black Glass	<b>923-757</b>	940	615	31
ZC Glass**	White Glass	<b>923-950</b>	940	615	31

## STUDIO 1 SLIMLINE MONACO INFORMATION

Monaco**	Concrete	<b>923-089</b>	1220	1379	225
Ext. Piece	Concrete	<b>923-114</b>	1220	300	225

## STUDIO 2 SLIMLINE FRAME INFORMATION

Frame	Frame Finish	Product Code	Frame Size (mm)		
			w	h	d
Profil	Anthracite	<b>8717BFANO2</b>	1036	510	12.5
Steel 2	Graphite	<b>923-556</b>	1500	528	27
Expression	Graphite	<b>923-709</b>	1140	614	40
Verve	Graphite	<b>923-514</b>	1500	528	53
Glass	Black Glass	<b>923-535</b>	1500	528	29
ZC Steel**	Graphite	<b>923-720</b>	1140	615	27
ZC Glass**	Black Glass	<b>923-772</b>	1140	615	31

‡ Available as an upgrade to Studio fires with a log effect fuel bed

\*\* Please see page 54 for further dimensions. ZC Frames come complete with the Zero Clearance Box.

## STUDIO 1 SLIMLINE OPTIONS

Product Code	Description
<b>8727BFEK01</b>	Edge fitting kit for BF †
<b>8727BFCW01</b>	Cool Wall fitting kit for BF †
<b>923-826</b>	Black Reeded Lining Set ‡
<b>923-765</b>	Brick-effect Lining Set ‡
<b>923-124</b>	Black Glass Lining Set ‡
<b>999-620</b>	Remote system mains adaptor

## STUDIO 2 SLIMLINE OPTIONS

Product Code	Description
<b>8727BFEK02</b>	Edge fitting kit for BF †
<b>8727BFCW02</b>	Cool Wall fitting kit for BF †
<b>923-226</b>	Black Reeded Lining Set ‡
<b>923-273</b>	Brick-effect Lining Set ‡
<b>923-314</b>	Black Glass Lining Set ‡
<b>999-620</b>	Remote system mains adaptor



# Studio 1 & 2 Slimline Fires (continued)

## STUDIO SLIMLINE DIMENSIONS (mm)

Dimensions are the same for both models, except where specified

### TOP VIEW

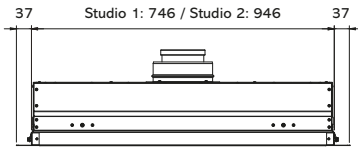

### FRONT AND SIDE VIEW

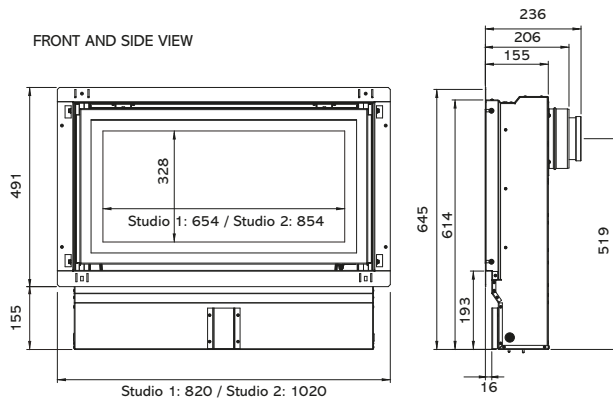

The Studio 1 and 2 Slimline comes complete with a specific rear exit balanced flue termination kit (8526) included.

395 x 200 x 200 mm (H x W x D) Guard supplied. Cut to length as required on site.

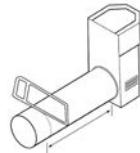

## ZERO CLEARANCE FRAME DIMENSIONS (mm)

Dimensions are the same for both models, except where specified

### ZERO CLEARANCE BOX DIMENSIONS

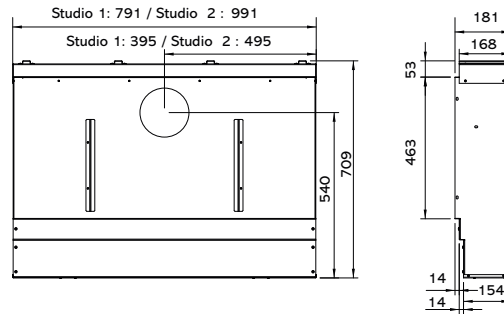

### FRAME DIMENSIONS

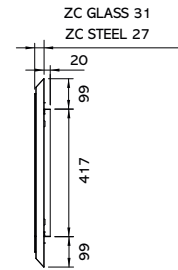
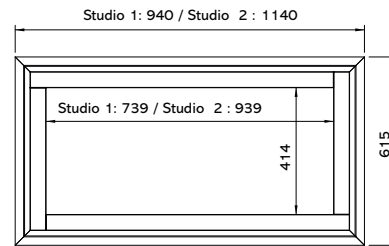

ZC GLASS 31  
ZC STEEL 27

### COMPLETE PRODUCT DIMENSIONS (FRAME & ZERO CLEARANCE BOX)

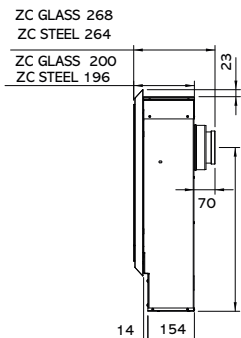
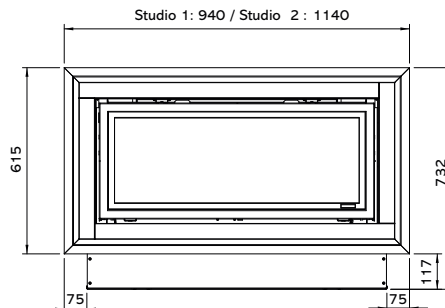

ZC GLASS 268  
ZC STEEL 264  
ZC GLASS 200  
ZC STEEL 196

## MONACO SURROUND DIMENSIONS (mm)

### CENTRALLY ALIGNED FIRE

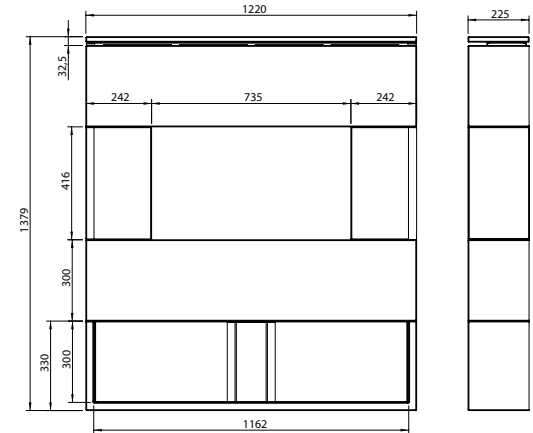

### OFFSET FIRE

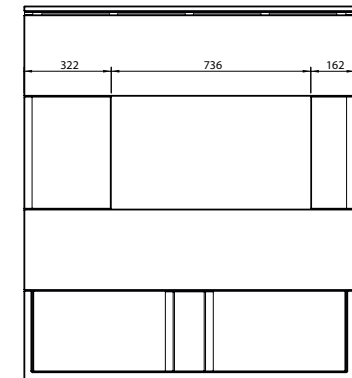

### EXTENSION PIECE

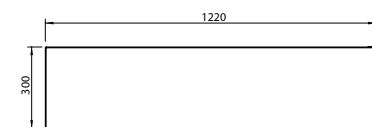

# Studio 1 Freestanding

Supplied with Programmable Thermostatic Remote

## STUDIO 1 FREESTANDING FIRE INFORMATION

Product Code	Flue Type	Gas Type	Fuel Effect	Heat Input	Heat Output	Efficiency	Efficiency Class	Lining
508-147	Conventional Flue	Nat. Gas	Logs	6.30kW	4.10kW	72%	E	Black Glass
508-589	Conventional Flue	LPG	Logs	6.90kW	4.60kW	72%	E	Black Glass

### LOG-EFFECT FUEL BED, CONVENTIONAL FLUE

508-147	Conventional Flue	Nat. Gas	Logs	6.30kW	4.10kW	72%	E	Black Glass
508-589	Conventional Flue	LPG	Logs	6.90kW	4.60kW	72%	E	Black Glass

### LOG-EFFECT FUEL BED, BALANCED FLUE

508-248	Balanced Flue	Nat. Gas	Logs	6.30kW	5.20kW	92%	A	Black Glass
508-597	Balanced Flue	LPG	Logs	6.30kW	5.30kW	92%	A	Black Glass

## STUDIO 1 FREESTANDING GAS DIMENSIONS (mm)

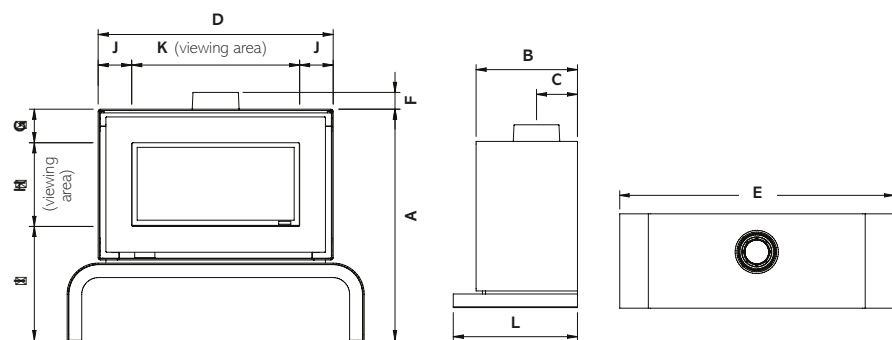

All sizes in mm	A	B	C	D	E	F	G	H	I	J	K	L
<b>Studio 1 Freestanding Bench</b>	896	396	CF: 148 BF: 160	910	1150	CF: 43 BF: 65	130	324	442	130	650	-
<b>Studio 1 Freestanding Plinth</b>	649	396	CF: 148 BF: 160	910	1105	CF: 43 BF: 65	130	324	195	130	650	485

## PLINTH & BENCH MOUNTING CHOICE (REQUIRED)

999-022	Studio 1 Freestanding Plinth - Black
999-101	Studio 1 Freestanding Bench - Black

## ACCESSORIES

923-517	Studio 1 CF - Black Reeded Lining Set
923-240	Studio 1 CF - Black Glass Lining Set
923-607	Studio 1 BF - Black Reeded Lining Set
923-282	Studio 1 BF - Black Glass Lining Set
999-620	Remote System Mains Adaptor

# Studio 2 Freestanding

Supplied with Programmable Thermostatic Remote

## STUDIO 2 FREESTANDING FIRE INFORMATION

Product Code	Flue Type	Gas Type	Fuel Effect	Heat Input	Heat Output	Efficiency	Efficiency Class	Lining
508-094	Conventional Flue	Nat. Gas	Logs	8.50kW	6.90kW	81%	C	Black Glass
508-426	Conventional Flue	LPG	Logs	8.50kW	6.90kW	81%	C	Black Glass

### LOG-EFFECT FUEL BED, CONVENTIONAL FLUE

508-094	Conventional Flue	Nat. Gas	Logs	8.50kW	6.90kW	81%	C	Black Glass
508-426	Conventional Flue	LPG	Logs	8.50kW	6.90kW	81%	C	Black Glass

### LOG-EFFECT FUEL BED, BALANCED FLUE

508-027	Balanced Flue	Nat. Gas	Logs	8.50kW	7.00kW	92%	A	Black Glass
508-444	Balanced Flue	LPG	Logs	8.00kW	6.80kW	92%	A	Black Glass

## STUDIO 2 FREESTANDING GAS DIMENSIONS (mm)

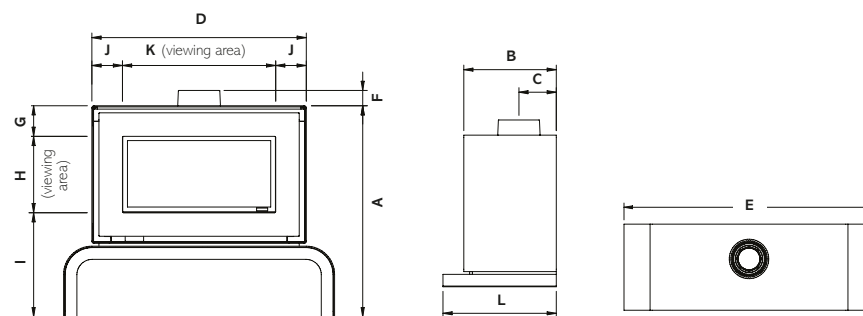

All sizes in mm	A	B	C	D	E	F	G	H	I	J	K	L
<b>Studio 2 Freestanding Bench</b>	896	396	CF: 148 BF: 160	1110	1350	CF: 43 BF: 65	130	324	442	130	850	-
<b>Studio 2 Freestanding Plinth</b>	649	396	CF: 148 BF: 160	1110	1305	CF: 43 BF: 65	130	324	195	130	850	485

## PLINTH & BENCH MOUNTING CHOICE (REQUIRED)

999-048	Studio 2 Freestanding Plinth - Black
999-087	Studio 2 Freestanding Plinth - White
999-127	Studio 2 Freestanding Bench - Black
999-166	Studio 2 Freestanding Bench - White

## ACCESSORIES

923-744	Studio 2 CF - Black Reeded Lining Set
923-267	Studio 2 CF - Black Glass Lining Set
923-294	Studio 2 BF - Black Glass Lining Set
999-620	Remote System Mains Adaptor

# Your Home & Flue Requirements...

## Conventional Flue

Conventional flue systems are for Gazco's Open Fronted and some Glass Fronted gas fires. They are easily recognisable as either a conventional brick or stone chimney, or as a pre-fabricated chimney system. Should your home have neither at present, it is usually possible to have a pre-fabricated system installed in your home if required.



### Brick/Stone Chimney

(Class 1)

The chimney stack rises well above the roofline and is topped by a traditional chimney pot or gas terminal. This type of chimney relies on the natural circulation of heated air to expel the products of combustion up your chimney.

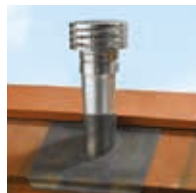

### Pre-fabricated Flues

(Class 1 & 2)

You will see a metal flue cowl on your roof. Some are all metal whilst others may terminate through a short rectangular pot (but without a chimney stack). These flues create the same circulation of heated air as a brick or stone chimney.

## Balanced Flue

Balanced flues work in conjunction with Gazco's Glass Fronted gas fires only. The appliance is completely sealed from the room into which it is installed (so there are no draughts and heating efficiency is increased) and a twin-wall pipe vents directly to an outside wall.



### Balanced Flue

(No chimney required)

Air for combustion is drawn in through the outer pipe whilst the inner pipe removes the combustion gases to the exterior of the property. Depending on the fire selected, the twin-walled pipe may exit horizontally through an external wall or vertically through the roof. Gazco offers a comprehensive range of balanced flue system components. Please refer to our dedicated Concentric Flue System brochure which can be requested from your retailer or viewed online at [www.gazco.com](http://www.gazco.com).

## No Air Vent Required (UK)



All fires shown with this symbol have the advantage of not normally requiring an air vent\*. Please discuss this in full with your local retailer.

\*Requirements in the Republic of Ireland are different.



# Balanced Flue Options

Gazco offers a comprehensive range of balanced flue system components. Please refer to our dedicated Concentric Flue System brochure which can be requested from your retailer or viewed online at [www.gazco.com](http://www.gazco.com).

Vertical from the top of the appliance

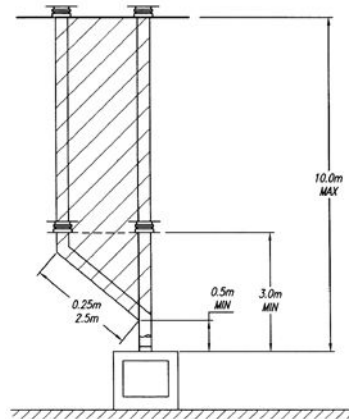

All Studio sizes

Vertical from the top of the appliance then horizontally out

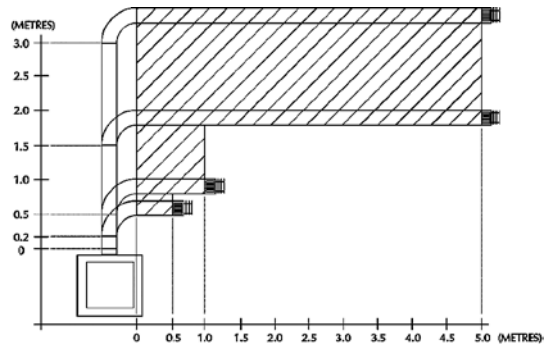

Studio 1

Vertical from the top of the appliance then horizontally out  
- Studio 2 requires a minimum 700mm rise from the top of the unit

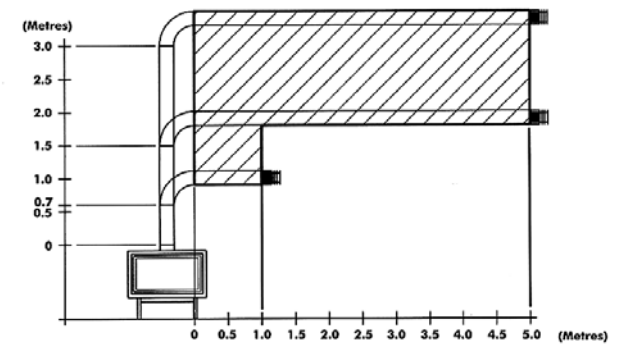

Studio 2

Vertical from the top of the appliance then horizontally out

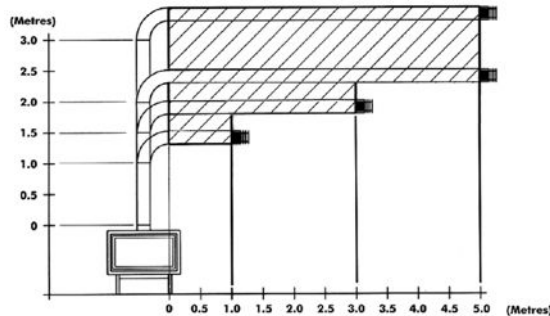

Studio 2 Duplex - Nat Gas

Vertical from the top of the appliance then horizontally out  
- Studio 3 requires a minimum 1000mm rise from the top of the unit

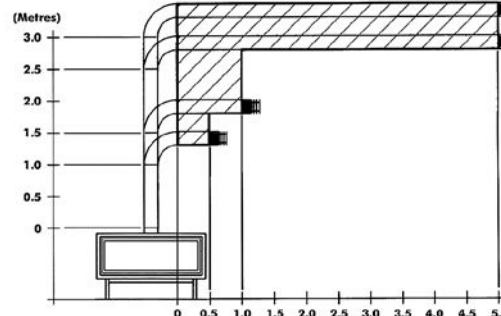

Studio 3

# Important Information

## Technical Specifications

All specifications given in this brochure are approximate. Actual specifications for each individual product will vary according to model. Your Gazco retailer will be pleased to provide any further information you require. Alternatively you may view or download specification sheets from [www.gazco.com](http://www.gazco.com).

## Installation and Safety

Gazco gas fires must be fitted by a qualified gas installer (Gas Safe registered in the United Kingdom or Bord Gáis registered in the Republic of Ireland) who should also verify the proposed site conditions are fully suitable for the product selected. Complete installation instructions for many models can be obtained prior to purchase by viewing or downloading them from [www.gazco.com](http://www.gazco.com). Please note that all parts of these fires, particularly the glass panel in the door, become extremely hot during operation and can result in serious injury and burns if touched. It is therefore recommended that a fireguard complying with BS 8423:2002 is used in the presence of young children, the elderly or infirm.

## Colours/Flame pictures

Owing to variations in studio lighting and printing inks, the finishes/colours of fires illustrated in this brochure may differ slightly from actual models. Before purchasing, please ask your retailer to show you finish/colour samples. Whilst all the flame pictures shown in this brochure are of actual fires, flame pictures may vary depending on the installation, flue conditions and geographical/surrounding features that may effect the efficiency of the flue.

## Care and maintenance

Traditional materials, such as polished steel and brass, tarnish on contact with air, especially when

also exposed to heat. To help minimise this effect, we recommend fires receive regular treatment with suitable proprietary cleaners. Additionally, please remember that gas fires will require servicing annually by a qualified gas installer Gas Safe registered in the United Kingdom or RGII registered in the Republic of Ireland).

## Warranty and Product Improvement

Your Gazco Expert Retailer will provide you with a Two Year Warranty for your new gas fire. This can be extended to a Five Year Warranty provided your fire has been registered with Gazco. The second and subsequent years are dependant on the appliance being serviced 12 months after installation and annually thereafter and exclude certain consumable parts. Fires purchased outside of Gazco's Expert Retailer Network will carry a standard 1 Year Non-Extendable Warranty, or minimum statutory warranty for your country. Full warranty terms and conditions are available to view at [www.gazco.com](http://www.gazco.com).



Gazco pursue a policy of continuous product improvement, therefore, whilst our products are correct at the time of the photography, we reserve the right to make alterations and amendments. Exact product details should be discussed with your retailer at the time of purchase.

## Air Ventilation for Gas Fires

To comply with gas appliance installation regulations, all Glass Fronted Studio 2 fires with a conventional flue require additional ventilation into your room. For further information, please consult either your Gazco retailer or the Gazco Technical Information on our website [www.gazco.com](http://www.gazco.com) to confirm the ventilation required. All other fires featured in this brochure do not require additional ventilation.

Gazco gratefully acknowledges the assistance of the following companies with photographic settings:

**Furnishings and Ornaments:-** [www.amara.com](http://www.amara.com); [www.furniturevillage.co.uk](http://www.furniturevillage.co.uk); [www.fwhomestores.co.uk](http://www.fwhomestores.co.uk); [www.lauraashley.com](http://www.lauraashley.com); [www.faginsantiques.com](http://www.faginsantiques.com); [www.theorangetree.co.uk](http://www.theorangetree.co.uk); [www.habitat.co.uk](http://www.habitat.co.uk); [www.houseoffraser.co.uk](http://www.houseoffraser.co.uk); [www.ashorejewellery.co.uk](http://www.ashorejewellery.co.uk); [www.eclectique.co.uk](http://www.eclectique.co.uk); [www.debenhams.com](http://www.debenhams.com); [www.next.co.uk](http://www.next.co.uk); [www.mokodirect.co.uk](http://www.mokodirect.co.uk); [www.marksandspencer.com](http://www.marksandspencer.com); [www.rockettstgeorge.co.uk](http://www.rockettstgeorge.co.uk); [www.frenchconnection.com](http://www.frenchconnection.com); [www.wayfair.co.uk](http://www.wayfair.co.uk); [www.urbanoutfitters.com/uk](http://www.urbanoutfitters.com/uk); [www.tkmaxx.com](http://www.tkmaxx.com); [www.homesense.com](http://www.homesense.com); [www.johnlewis.com](http://www.johnlewis.com); [www.coxandcox.co.uk](http://www.coxandcox.co.uk); [www.urbanara.co.uk](http://www.urbanara.co.uk) **Lighting:-** [www.amoslighting.co.uk](http://www.amoslighting.co.uk) **Wood Mantels:-** [www.stovax.com](http://www.stovax.com) **Stone Mantels:-** [www.farmington.co.uk](http://www.farmington.co.uk); [www.bnsp.co.uk](http://www.bnsp.co.uk); [www.grandisson.com](http://www.grandisson.com); [www.rudloe-stone.com](http://www.rudloe-stone.com) **Wood flooring:-** [www.beechbros.co.uk](http://www.beechbros.co.uk) **Tiles & Stone floors:-** [www.originalstyle.com](http://www.originalstyle.com); [www.wallsandfloors.co.uk](http://www.wallsandfloors.co.uk) **Televisions:-** [www.heavitreeradio.co.uk](http://www.heavitreeradio.co.uk) **Plants:-** [www.stbridgetnurseries.co.uk](http://www.stbridgetnurseries.co.uk)  
**Art:-** [www.easyart.com](http://www.easyart.com); [www.desenio.co.uk](http://www.desenio.co.uk)

# Gazco Gas Fires



Reflex 105-3 (three-sided fire) with EchoFlame Black Glass lining



Riva2 500 Evoke Glass with White Glass front and Graphite rear with EchoFlame Black Glass lining

Alongside the Studio Gas fire range, Gazco offer the stunning Reflex and Riva2 gas fires. Featuring realistic logs, superb flames and a choice of lining and frame options, these versatile portrait and landscape fires instantly create a focal point which can be tailored to suit your interior.

To view the Gazco Reflex and Riva2 brochures visit [www.gazco.com](http://www.gazco.com) or speak to your local Gazco retailer.



# WIN

 the cost of your product back!\*

For further home inspiration you can **view real life installations** at our Customer Showcase page and share your thoughts and photos of your new stove or fire installation to enter our draw!

- We will publish your entry on our Customer Showcase
- You will be entered into a draw for the chance to win the cost of your product back
- **Gain a second entry** by registering your product online for your free extended warranty at [gazco.com/registration](http://gazco.com/registration)



"We wanted a stove to give a cosy feel to the room"



"So pleased we chose this gas alternative to a log burning stove"



"We are still over the moon that we won the competition"

View real life installations and submit your review at [gazco.com/customershowcase](http://gazco.com/customershowcase)

\* Terms and conditions apply. See online for details





Studio 1 Freestanding on Bench with Log-effect fuel bed and EchoFlame Black Glass lining



Gazco Limited, Spitfire Avenue, Skypark, Clyst Honiton, Exeter, EX5 2FR

Tel: 01392 261999 • Email: info@gazco.com  
Export Sales: 00 44 1392 261990

gazco.com   



Find your Local Expert Retailer

Find your nearest retailer by visiting:  
[www.gazco.com/retailers](http://www.gazco.com/retailers)

Paper sourced from sustainable forests and printed using vegetable-based inks

Your Gazco stockist:

GZSTUDIO1023



A member of the Stovax Group © Copyright Gazco Ltd 2023 E & O E